

Note :

- ISO 8573-1:2010[4:4:3]  
The clamp air and internal pressure air must comply with following quality classes as per ISO 8573-1:2010[4:4:3]
- The accuracy is compensated
- The thermal protection device\*1、military connector(Female)\*2、key\*2 are supplied by HIWIN.

Circuit Specification-2			
No.	Item	Spec.	Note
C-E1	Power Connection	MS3100A-20-4P	-
C-E2	Thermal Motor Protection	MS3100A-20-29P	-
C-E3	Encoder Signal	MS3100A-20-29P	-
C-H1	Coolant(In)	ø8	q ≥ 2.87 l/min; Δθ ≤ 5K; Δp ≤ 1 bar
C-H2	Coolant(Out)	ø8	q ≥ 2.87 l/min; Δθ ≤ 5K; Δp ≤ 1 bar
C-H3	Clamp Air	ø8	p = 6.3 ± 0.2 bar (note 1)
C-H4	Internal Pressure Air	ø8	Δp ≤ 1 bar

RT Specification	
Item	Spec.
Table Diameter(mm)	170
Center Height(mm)	135
T-slot Width(mm)	12H8
Bearing I,D(mm)	100
Torque Motor Type	TMRW 45
Max. Speed with water cooling(rpm)	200
Continuous Torque with water cooling(Nm)	106
Peak Torque with water cooling.(Nm)	203
Continuous Current with water cooling(A)	9
Peak Current with water cooling.(A)	24.3
Encoder interface	Renishaw RA23F
Continuous power with water cooling(W)	2220
Accuracy(arc-sec)	±5 (note2)
Repeatability(arc-sec)	4
Clamping Type	Pneumatic
Clamping Torque(Nm)	300
Net Weight(kg)	~95
Load Weight(kg)	50
Controller Support	FANUC

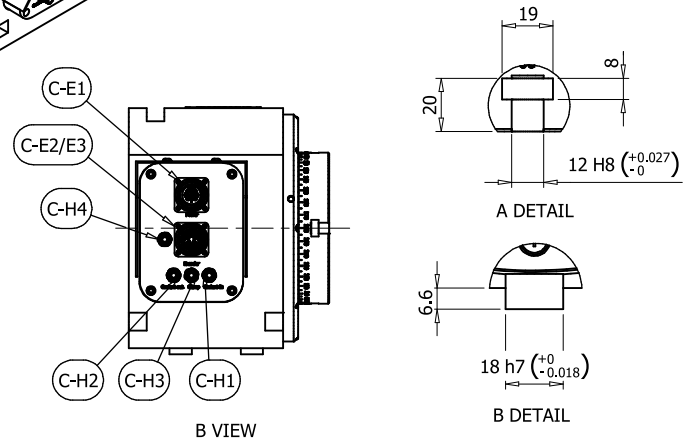
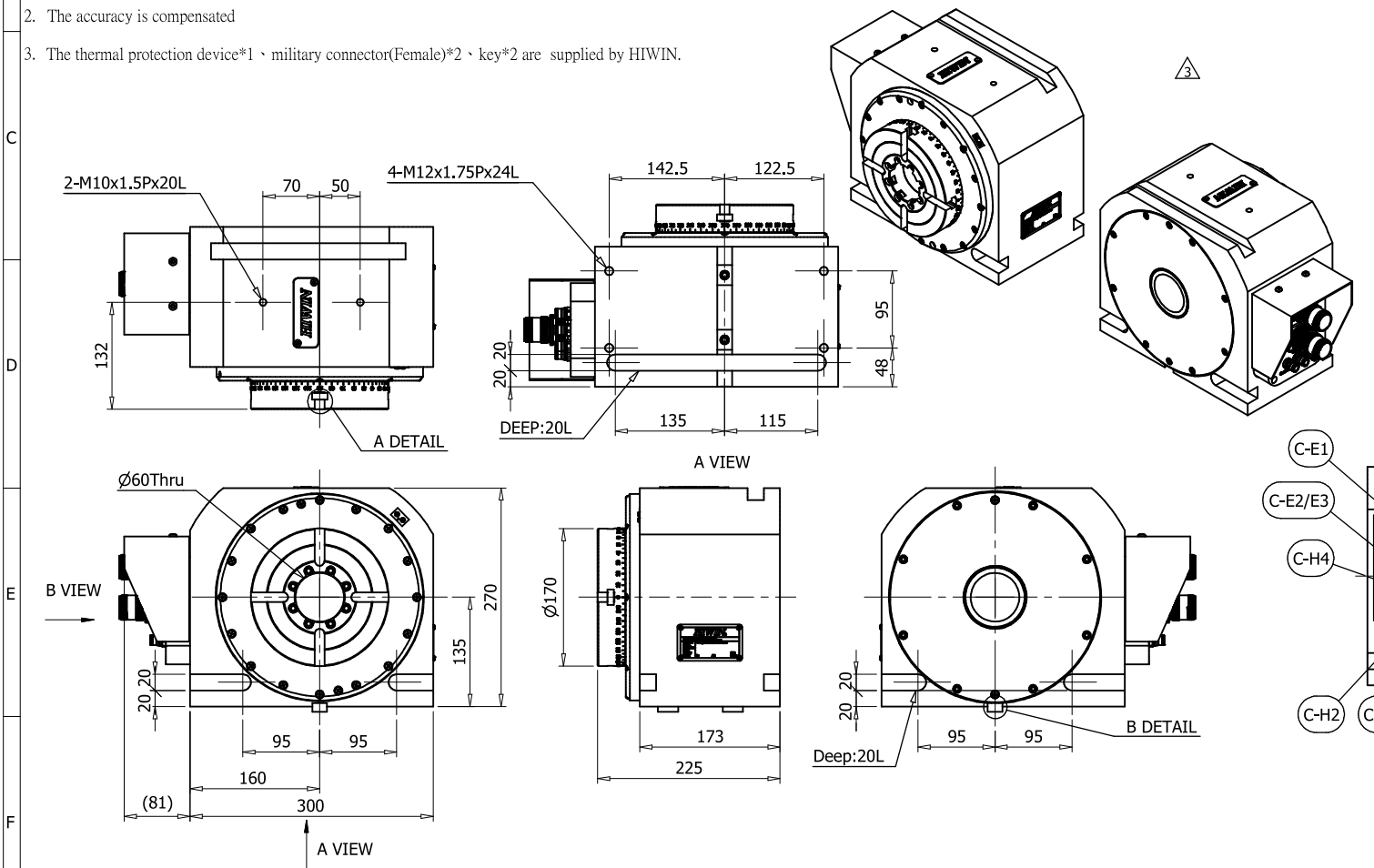

Modification	C3	Description Record	2022/03/27	Date	Check
--------------	----	--------------------	------------	------	-------

mm						
UP	6	120	300	600	1200	OVER 2400
TO	±0.05	±0.1	±0.2	±0.3	±0.4	±0.5

1	Rotary Table		
*	AS00549D		
AS00549D	RCV-170		2022/3/27



### C-E1 for Rotary Axis TM Power Connector

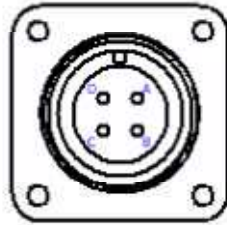

MS3100A-20-4P  
23A, 4P(2.5mm<sup>2</sup>), Male

PIN	Wire Markers	Color/Description
A	U	Black
B	V	Black
C	W	Black
D	PE	Yellow/Green

### C-E2/E3 for Rotary Axis TM Temperature and Encoder Connector

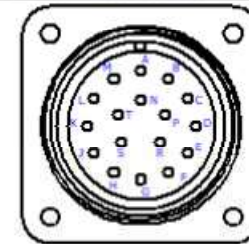

MS3100A-20-29P  
17P, 0.75mm<sup>2</sup>, Male

PIN	Wire Markers	Color/Description
A	PTC+	Blue
B	PTC-	Yellow
C	TEMP-	Brown
D	TEMP+(U)	White
E	TEMP+(V)	Gray
F	TEMP+(W)	Pink
G	SD	Gray
H	SD*	Pink
J	REQ	Violet
K	REQ*	Yellow
L	5V	Brown
M	Spare	Spare
N	0V	White
P	0V	Green
R	Shield	Shield

1	Rotary Table	
*	AS00549D	
AS00549D	RCV-170	2021/3/27

mm						
UP	6	120	300	600	1200	OVER
TO	±0.05	±0.1	±0.2	±0.3	±0.4	±0.5
						±0.8

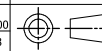

HIWIN TECHNOLOGIES

D
2 / 2