

**HIWIN® MIKROSYSTEM**

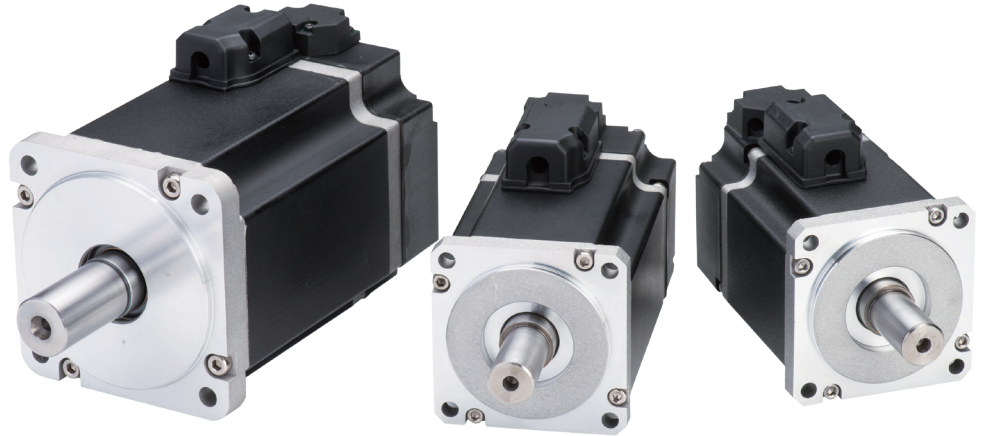

# E Series AC Servo Motor

User Manual

## Related Documents

Through related documents, users can quickly understand the positioning of this manual and the correlation between manuals and products. Go to HIWIN MIKROSYSTEM's official website ([https://www.hiwinmikro.tw/Downloads/ManualOverview\\_EN.htm](https://www.hiwinmikro.tw/Downloads/ManualOverview_EN.htm)) → Download → Manual Overview for details.

# Approvals

Approvals		Drive	Motor
CE requirement 	EMC requirement	EN61800-3 EN55011 EN61000-6-2 EN61000-6-4 EN61000-2-4 IEC60146-1-1 IEC61000-2-1	EN55011 EN61000-6-2 EN61000-6-4
	Low voltage requirement	LVDS:EN61800-5-1	EN60034-1 EN60034-5
UL requirement		UL:E348161	UL1004-1 UL1004-6

# Table of Contents

1.	General information.....	1-1
1.1	Revision history .....	1-2
1.2	About this manual .....	1-4
1.3	General precautions .....	1-5
1.4	Safety instruction .....	1-11
1.5	Copyright .....	1-15
1.6	Manufacturer information.....	1-15
1.7	Product monitoring.....	1-15
2.	Basic safety information .....	2-1
2.1	Overview .....	2-2
2.2	Basic safety notices .....	2-2
2.3	Reasonably foreseeable misuse .....	2-3
2.4	Conversions and modifications.....	2-3
2.5	Residual risks .....	2-3
2.6	Personnel requirements.....	2-4
2.7	Protective equipment.....	2-4
2.8	Labels on servo motor .....	2-5
3.	Product description .....	3-1
3.1	Servo motor description.....	3-2
3.2	Main components of servo motor .....	3-3
3.3	Order code .....	3-4
3.3.1	Model explanations .....	3-4
3.3.1.1	E series AC servo motor.....	3-4
3.3.1.2	E1 Series Servo Drive .....	3-5
3.3.1.3	E2 Series Servo Drive .....	3-7
3.3.1.4	Power cable.....	3-8
3.3.1.5	Encoder cable .....	3-9
3.3.1.6	Combination of E series AC servo motor, servo drives and cable .....	3-10
3.3.2	Technical data .....	3-12
3.3.2.1	EM1-C-M-05-2-□-□-0-□-technical data .....	3-12
3.3.2.2	EM1-C-M-10-2-□-□-0-□-technical data .....	3-13
3.3.2.3	EM1-C-M-20-2-□-□-0-□-technical data .....	3-14
3.3.2.4	EM1-C-M-40-2-□-□-0-□-technical data .....	3-15
3.3.2.5	EM1-C-M-75-2-□-□-0-□-technical data .....	3-16
3.3.2.6	EM1-A-M-1K-2-□-□-0-□-technical data.....	3-17

3.3.2.7	EM1-D-M-1A-2-□-□-0-□-technical data .....	3-18
3.3.2.8	EM1-D-M-2K-2-□-□-0-□-technical data .....	3-19
3.3.3	Mechanical overview .....	3-21
3.3.4	Selection calculation .....	3-24
3.3.4.1	Mechanical mechanism .....	3-24
3.3.4.2	Motion profile .....	3-26
3.3.4.3	Load inertia calculation .....	3-27
3.3.4.4	Motor speed calculation .....	3-28
3.3.4.5	Motor torque calculation .....	3-29
3.3.4.6	Regenerative energy calculation .....	3-31
3.3.5	Operating instructions .....	3-33
3.3.6	De-rating curve .....	3-34
4.	Transport and setup .....	4-1
4.1	Delivery .....	4-2
4.1.1	Delivery state .....	4-2
4.1.2	Scope of delivery .....	4-2
4.1.3	Delivery ambient conditions .....	4-2
4.2	Transport to the installation site .....	4-3
4.3	Requirements at the installation site .....	4-4
4.4	Storage .....	4-5
4.5	Unpacking and setup .....	4-6
5.	Assembly and connection .....	5-1
5.1	Mechanical installation .....	5-2
5.1.1	Installation environment .....	5-2
5.1.2	Tools and equipment .....	5-3
5.1.3	Servo motor installation .....	5-4
5.1.3.1	Motor .....	5-4
5.1.3.2	Oil seal .....	5-7
5.1.3.3	Key .....	5-8
5.1.3.4	Belt .....	5-11
5.1.3.5	Coupling .....	5-12
5.1.3.6	Safety brakes .....	5-15
5.2	Electrical installation .....	5-17
5.2.1	Motor cable pin assignment .....	5-17
5.2.1.1	Motor power cable connector .....	5-17
5.2.1.2	17 bit / 23 bit Incremental encoder cable connector .....	5-21
5.2.1.3	17 bit / 23 bit Absolute encoder cable connector .....	5-23
5.2.1.4	Allowable bending radius .....	5-27
5.2.2	Electrical connection .....	5-28

6.	Commissioning.....	6-1
6.1	Commissioning .....	6-2
6.1.1	Flow chart for tuning .....	6-2
6.1.2	Tuning function.....	6-3
6.1.3	Precautions during tuning .....	6-4
7.	Maintenance and cleaning .....	7-1
7.1	Maintenance .....	7-2
7.2	Cleaning.....	7-4
7.2.1	Test run .....	7-5
8.	Disposal .....	8-1
8.1	Waste disposal.....	8-2
8.1.1	General .....	8-2
8.1.2	Tools and equipment.....	8-3
8.1.3	Decommissioning.....	8-3
8.1.4	Disposal .....	8-4
9.	Troubleshooting.....	9-1
9.1	Troubleshooting .....	9-2
9.1.1	Troubleshooting form .....	9-3
10.	Declaration of incorporation .....	10-1
10.1	Declaration of incorporation.....	10-2
11.	Appendix.....	11-1
11.1	Glossary.....	11-2
11.2	Unit conversion .....	11-3
11.3	Tolerances and hypotheses .....	11-5
11.3.1	Tolerances .....	11-5
11.3.2	Hypotheses .....	11-5
11.4	Supplementary formula.....	11-6
11.5	Optional accessories .....	11-7
11.5.1	Accessory kit.....	11-7
11.5.2	Power supply filter and accessories.....	11-7
11.5.3	Accessories for absolute encoder.....	11-7
11.5.4	Regenerative resistor .....	11-7
11.6	Customer request form .....	11-8

# 1. General information

---

1.	General information.....	1-1
1.1	Revision history .....	1-2
1.2	About this manual .....	1-4
1.3	General precautions .....	1-5
1.4	Safety instruction .....	1-11
1.5	Copyright .....	1-15
1.6	Manufacturer information.....	1-15
1.7	Product monitoring.....	1-15

## 1.1 Revision history

The version of the manual is also indicated on the bottom of the front cover.

MC03UE01-2309\_V1.3

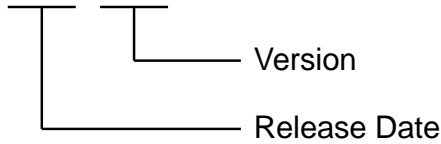

Release Date	Version	Applicable Product	Revision Contents
Jan. 12 <sup>th</sup> , 2024	1.3	E Series AC Servo Motor	<ol style="list-style-type: none"> <li>1. Update section 2.6 <b>Personnel requirements.</b></li> <li>2. Update section 5.1.2 <b>Tools and equipment.</b></li> <li>3. Update section 7.1 <b>Maintenance.</b></li> <li>4. Update section 8.1.1 <b>General.</b></li> <li>5. Update section 8.1.3 <b>Decommissioning.</b></li> </ol>
Sep. 30 <sup>th</sup> , 2023	1.2	E Series AC Servo Motor	<ol style="list-style-type: none"> <li>1. Update the title of this manual.</li> <li>2. Update section 3.3.1.1 <b>E series AC servo motor.</b></li> <li>3. Add section 3.3.1.2 <b>E1 Series Servo Drive.</b></li> <li>4. Add section 3.3.1.3 <b>E2 Series Servo Drive.</b></li> <li>5. Update section 3.3.1.4 <b>Power cable.</b></li> <li>6. Update section 3.3.1.5 <b>Encoder cable.</b></li> <li>7. Update section 3.3.1.6 <b>Combination of E series AC servo motor, servo drives and cable.</b></li> <li>8. Update section 3.2 <b>Main components of servo motor.</b></li> <li>9. Update section 3.3.2.1 <b>EM1-C-M-05-2-□-□-0-technical data.</b></li> <li>10. Update section 3.3.2.4 <b>EM1-C-M-40-2-□-□-0-□-technical data.</b></li> <li>11. Update section 3.3.2.8 <b>EM1-D-M-2K-2-□-□-0-□-technical data.</b></li> <li>12. Update section 3.3.6 <b>De-rating curve.</b></li> <li>13. Add section 5.1.3.6 <b>Safety brakes.</b></li> <li>14. Update section 5.2.1.1 <b>Motor power cable connector.</b></li> <li>15. Update section 5.2.1.2 <b>17 bit / 23 bit Incremental encoder cable connector.</b></li> </ol>



Release Date	Version	Applicable Product	Revision Contents
			<ul style="list-style-type: none"><li>16. Update section 5.2.1.3 <b>17 bit / 23 bit Absolute encoder cable connector.</b></li><li>17. Update section 7.1 <b>Maintenance.</b></li><li>18. Delete section 7.2.1.1 <b>Inspection procedure for servo motor.</b></li><li>19. Update section 11.5.1 <b>Accessory kit.</b></li><li>20. Update section 11.5.2 <b>Power supply filter and accessories.</b></li><li>21. Add section 11.5.3 <b>Accessories for absolute encoder.</b></li><li>22. Add section 11.5.4 <b>Regenerative resistor.</b></li></ul>
May. 31 <sup>st</sup> , 2023	1.1	E Series AC Servo Motor	Rearrange the chapters.
Mar. 6 <sup>th</sup> , 2020	1.0	E Series AC Servo Motor	First edition.

## 1.2 About this manual

This manual explains the features of the product, possibilities for use, operating conditions and operation limits of E series AC servo motor.

This manual is only intended for the use of trained specialists in automation and control engineering who are familiar with the applicable national standards. It is the duty of the technical personnel to use the manual published at the respective time of each installation and commissioning.

The responsible staff must ensure the application or use of the products described satisfy all the requirements for safety, including all the relevant laws, regulations guidelines and standards.

Be sure to refer to this manual and to keep this manual in a location where it can be accessed at any time.

### ■ Documents

For configuring, you require the catalog or manual as print version or online with the following website.

<https://www.hiwinmikro.tw/en/product/ac-servo-motor/ac-servo-motor-e1-series>

## 1.3 General precautions

Before using the product, please carefully read through this manual. HIWIN MIKROSYSTEM is not responsible for any damage, accident or injury caused by failure in following the installation instructions and operating instructions stated in this manual.

- Before installing or using the product, check the package to see if it has been damaged or broken. If there is any damage, please contact the sales representatives of HIWIN MIKROSYSTEM or agents or dealers.
- Check if the cables have been damaged and if they can be used for connection.
- Read the performance specifications indicated on the label or in the enclosed document before installation. Install the product based on the limit of the performance with installation guide and only use genuine spare parts from HIWIN MIKROSYSTEM.
- Please comply with the instructions and regulations when using the product.
- AC servo motor must be operated within the specified performance limits (see technical information and the approval drawing).
- AC servo motor must only be used for the intended purpose as described. Any other use of the AC servo motor shall be considered as improper usage. HIWIN MIKROSYSTEM is not responsible for any product damage or personal injury caused by this.
- For safe operation of the AC servo motor, appropriate safety precautions must be taken to protect the motor against overload.
- Servo motors must not be used outdoors or in potentially explosive environments.
- Do not disassemble or modify the product by yourselves. The product has been designed with structural calculations, computer simulations, and physical testing. Do not disassemble or modify the product without the permission of professionals.
- Children are not allowed to operate this product.
- People who have physical or mental disease or who do not have experience with the use of related products should not be allowed to use this product unless they are accompanied by supervisors or personnel familiar with the product to ensure their safety.
- Damaged products must not be installed or operated.

- If the information of registration does not match with your purchasing or if there are any questions related to the product, please contact the sales representatives of HIWIN MIKROSYSTEM or agents or dealers.

HIWIN MIKROSYSTEM offers 1-year warranty for the product. The warranty does not cover damage caused by improper usage (refer to the precautions and instructions stated in this manual) or natural disaster.

- Protective requirement

Table 1.3.1

Operating Phase	Personal Protective Equipment
Normal Operation	In the vicinity of AC servo motor, the following personal protective equipment is required: <ul style="list-style-type: none"> <li>✓ Safety shoes</li> <li>✓ Protective helmet</li> <li>✓ Protective gloves</li> </ul>
Cleaning	When cleaning AC servo motor, the following personal protective equipment is required: <ul style="list-style-type: none"> <li>✓ Safety shoes</li> <li>✓ Protective helmet</li> <li>✓ Protective gloves</li> <li>✓ Protective goggles</li> </ul>
Maintenance	When carrying out maintenance and repairs, the following personal protective equipment is required: <ul style="list-style-type: none"> <li>✓ Safety shoes</li> <li>✓ Protective helmet</li> <li>✓ Protective gloves</li> </ul>

■ Installation precautions

 **WARNING**

**Risk of personal injury or damage to property.**

- ◆ Follow the technical instruction and install the AC servo motor at a location with bearable load.
- ◆ When installing, do not impact or strike the motor.
- ◆ When installing, prevent foreign objects from entering the product.
- ◆ The spacing for installing the AC servo motor, servo drive, controller and other machines should follow specifications.
- ◆ When installing, please set up an external emergency stop loop that can immediately stop the product and cut off power.

■ Wiring precautions

 **WARNING**

**Risk of personal injury or damage to property.**

- ◆ Ensure wiring is correctly performed. Otherwise, it may lead to product malfunction or burn-out. There could be a risk of injury or fire.
- ◆ Before using the product, carefully read through the specification noted on product label, and ensure the product is used with power supply specified in product requirement.
- ◆ Check if the wiring is correct. Incorrect wiring may make the AC servo motor operate abnormally, or even cause permanent damage to the motor.
- ◆ Select extension cable with shield. The shield must be grounded.

 **CAUTION**

**Risk of personal injury.**



- ◆ Ensure the AC servo motor is correctly grounded.
- ◆ The resistance of grounding terminal connection shall be less than 10Ω when the input voltage of the drive is 400V; less than 50Ω when it is 220V; less than 100Ω when it is 110V.

## ■ Operation precautions

 **WARNING****Risk of personal injury or damage to property.**

- ◆ Please follow the requirements of installation direction.
- ◆ Avoid excessive friction when the motor is running.
- ◆ Ensure there is no object in the motion range of the system.
- ◆ Before starting the AC servo motor, ensure the main switch is on.
- ◆ Before transmitting electricity, ensure there is at least one ground wire connecting to all electrical products.
- ◆ Do not directly touch the motor parts after the AC servo motor is assembled.
- ◆ Do not operate the product in an environment that exceeds its rated load.
- ◆ If any abnormal odor, noise, smoke, temperature rise or vibration is detected, stop the AC servo motor and cut off the power immediately.

## ■ Storage precautions

 **CAUTION****Risk of damage to property.**

- ◆ Follow the precautions of AC servo motor storage conditions.
- ◆ Do not store the product in an inflammable environment or with chemical agents.
- ◆ Do not store the product in a place with humidity, dust, harmful gases or liquids.
- ◆ Clean and protect used AC servo motor before storage.
- ◆ When storing AC servo motor, attach signs warning of magnetic fields.
- ◆ Storage conditions must comply with EN 60721-3-1(Refer to the table below for Storage conditions)
- ◆ Motor can be stored for up to two years indoor with the following conditions:
  - (1) Dry
  - (2) Dust-free
  - (3) No vibration
  - (4) Good ventilation
  - (5) Resistance to extreme weather
  - (6) Indoor air does not contain corrosive gases
  - (7) Prevent motor vibration and moisture
- ◆ If no dry storage environment is available, the following measures need to be taken:
  - (1) Wrap the motor with moisture-absorbing material, and then seal the motor.
  - (2) Put desiccant in the sealed package; the desiccant needs to be checked and replaced if necessary.
- ◆ Check the AC servo motor regularly.

Storage Conditions are listed as below:

Environmental Parameter	Description
Air temperature	-15°C ~70°C
Relative humidity	20%~80%
Rate of change of temperature	0.5°C /min
Air pressure	70 kPa ~106 kPa
Condensation	Not allowed
Formation of ice	Not allowed
Store the motor in an environment with good protection. (indoor/factory)	

■ Transportation precautions

**⚠ CAUTION**

**Risk of personal injury or damage to property.**

Follow the precautions of AC servo motor transport conditions.

- ◆ Carefully move the product to avoid damage.
- ◆ Do not apply excessive force to the product.
- ◆ Do not stack the product to avoid collapse.
- ◆ Transport conditions must comply with EN 60721-3-1 (Refer to the table below for transportation conditions).

■ Transportation Conditions

Environmental parameter	Description
Air temperature	-15°C~70°C
Relative humidity	20%~80%
Rate of change of temperature	0.5°C /min
Condensation	Not allowed
Formation of ice	Not allowed
Transport the motor in an environment with good protection. (indoor/factory)	

## ■ Maintenance precautions

 **WARNING****Risk of personal injury or damage to property.**

- ◆ Do not disassemble or modify the product.
- ◆ If the product malfunctions, do not repair the product by yourselves, please contact HIWIN MIKROSYSTEM for repairs.

## ■ Disposal precautions

 **WARNING****Risk of personal injury or damage to property.**

- ◆ If it is not correctly performed, it may cause personal injury or damage to material.
- ◆ If AC servo motor or related components (especially the rotor with strong magnets) are not handled correctly, it may cause personal injury, death or property damage.
- ◆ Please ensure that the AC servo motor and related components are disposed correctly.



## 1.4 Safety instruction

- Carefully read through this manual before installation, transportation, maintenance and examination. Ensure the product is correctly used.
- Carefully read through electromagnetic (EM) information, safety information and related precautions before using the product.
- Safety precautions in this manual are classified into “DANGER”, “WARNING” and “CAUTION”.

### **DANGER**

#### **Imminent danger!**

Indicates that death or severe personal injury will result if proper precautions are not taken.

### **WARNING**

#### **Potentially dangerous situation!**

Indicates that death or severe personal injury may result if proper precautions are not taken.

### **CAUTION**

#### **Moderate danger!**

Indicates that minor personal injury can result if proper precautions are not taken.

#### **Warning Signs**



No access for people with active implanted cardiac devices.



Substance hazardous to the environment!



Warning!



Warning of crushing of hands!









Warning of electricity!



Warning of hot surface!



Warning of magnetic field!

Mandatory Signs			
	Wear head protection!		Refer to user manual!
	Wear protective gloves!		Disconnect before carrying out maintenance or repair.
	Wear safety footwear!		Lifting point.
	Connect an earth terminal to the ground!		

 **DANGER**

**Danger from operation!**



- ◆ Do not repair the product by yourselves if something abnormal occurs. The product can only be repaired by HIWIN MIKROSYSTEM qualified technicians or sent back to HIWIN MIKROSYSTEM for repairs.
- ◆ Do not apply the load exceeding the specification standards to the product.
- ◆ Do not change product parts or remove product screws without authorization, or the product will be damaged. HIWIN MIKROSYSTEM is not responsible for any damage, accident or injury caused by this.
- ◆ Do not touch the product's keyway with hands.
- ◆ Do not touch the rotating parts of the product when it is operating.

 **DANGER**

**Danger from hot surface!**



- ◆ Do not place flammable materials around the AC servo motor, servo drive or regenerative resistor.
- ◆ Do not use the product in an environment with corrosive, flammable gases or flammable materials.
- ◆ Do not touch the surface of the AC servo motor, servo drive or regenerative resistor which will be hot while operating.

**⚠ DANGER**

**Danger from electrocution!**



- ◆ To prevent risk of electric shock, do not use damaged cables with excessive pressure or press and clamp the wire overly.
- ◆ Do not remove the cover, cables, or connector from AC servo motor while the power is ON.
- ◆ Do not touch wires or operate the equipment with wet hands.
- ◆ Do not use when wires are in contact with oil or water.

**⚠ DANGER**

**Danger from strong magnetic fields!**



- ◆ Strong magnetic fields around AC servo motor pose a health risk to persons with implants (e.g., cardiac pacemakers) that are affected by magnetic fields.
- ◆ People with implants are affected by magnetic fields should maintain a safe distance of at least 1 m from the AC servo motor.

**⚠ WARNING**

**Risk of personal injury or damage to property.**



- ◆ Read this manual and follow it carefully before using the product.
- ◆ If the product is used with excessive load, it may rise the temperature of the motor housing.
- ◆ There may be electromagnetic compatibility (EMC) problems in other environments.
- ◆ Do not use the product in an environment where it may be shocked. Do not directly strike the shaft or encoder, as hitting or pounding. HIWIN MIKROSYSTEM is not responsible for any damage, accident or injury caused by this.
- ◆ Do not pick up or place the motor only by pulling its cable or shaft.
- ◆ Since AC servo motor contains a precision encoder, please take sufficient measures to prevent electromagnetic interference or abnormal temperature change while using.
- ◆ The absolute encoder has an attached magnetic sensor. Do not operate magnetic equipment on the top of the encoder cover or around the encoder.

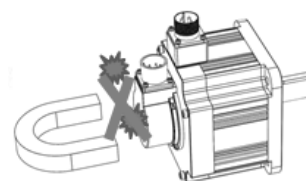
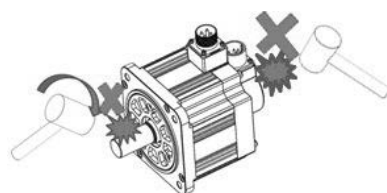

 **CAUTION****Risk of personal injury or damage to property.**

- ◆ Please follow the requirements of installation direction.
- ◆ Follow the technical instruction and install the AC servo motor at a location with bearable load.
- ◆ When installing, do not impact or strike the motor.
- ◆ When installing, prevent foreign objects from entering the product.
- ◆ The spacing for installing the AC servo motor, servo drive, controller and other machines should follow specifications.
- ◆ When installing, please set up an external emergency stop loop that can immediately stop the product and cut off power.

 **CAUTION****Risk of physical damage to watches and magnetic storage media.**

- ◆ Strong magnetic force may destroy watches and magnetizable data storage media near the AC servo motor!
- ◆ Do not bring watches or magnetizable data storage media in the vicinity (<300 mm) of the AC servo motor!

## 1.5 Copyright

This user manual is protected by copyright. Any reproduction, publication in whole or in part, modification or abridgement requires the written approval of HIWIN MIKROSYSTEM.

Note:

HIWIN MIKROSYSTEM reserves the right to change the contents of this manual or product specifications without prior notice.

## 1.6 Manufacturer information

Table 1.6.1 Manufacturer's details

Corp.	HIWIN MIKROSYSTEM CORP.
Address	No.6, Jingke Central Rd., Taichung Precision Machinery Park, Taichung 40852, Taiwan
Tel.	+886-4-23550110
Fax	+886-4-23550123
Sales E-mail	<a href="mailto:business@hiwinmikro.tw">business@hiwinmikro.tw</a>
Customer Service E-mail	<a href="mailto:service@hiwinmikro.tw">service@hiwinmikro.tw</a>
Website	<a href="http://www.hiwinmikro.tw">http://www.hiwinmikro.tw</a>

## 1.7 Product monitoring

Please inform HIWIN MIKROSYSTEM, the manufacturer of AC servo motor, of:

- Accidents.
- Potential sources of danger in AC servo motor.
- Anything in this user manual which is difficult to understand.

(This page is intentionally left blank.)

## 2. Basic safety information

---

2.	Basic safety information .....	2-1
2.1	Overview .....	2-2
2.2	Basic safety notices .....	2-2
2.3	Reasonably foreseeable misuse .....	2-3
2.4	Conversions and modifications.....	2-3
2.5	Residual risks .....	2-3
2.6	Personnel requirements.....	2-4
2.7	Protective equipment .....	2-4
2.8	Labels on servo motor .....	2-5

## 2.1 Overview

This chapter explains safety notices and risk management approach of using the product.

## 2.2 Basic safety notices

### **DANGER**

#### **Danger from strong magnetic fields!**



- ◆ Strong magnetic fields around AC servo motor pose a health risk to persons with implants (e.g., cardiac pacemakers) that are affected by magnetic fields.
- ◆ People with implants are affected by magnetic fields should maintain a safe distance of at least 1 m from the AC servo motor.

### **DANGER**

#### **Danger from operation!**



- ◆ If an abnormality occurs with this product, do not attempt to repair it yourself. This product should only be repaired by this company's qualified technical personnel or the product should be sent back to this company for repairs.
- ◆ Do not use the servo motor for loads that exceed its specification standards.
- ◆ Do not change servo motor parts or remove motor screws on your own because this can damage the servo motor. This company will not be responsible for any damage, accidents, or injuries caused by products that have been improperly tampered with.
- ◆ Do not touch the keyway of motor with hands.
- ◆ Never touch the rotating parts of the motor when the motor is operating.

### **DANGER**

#### **Danger from hot surface!**



- ◆ Do not place flammable materials around the AC servo motor, servo drive or regenerative resistor.
- ◆ Do not use the product in an environment with corrosive, flammable gases or flammable materials.
- ◆ Do not touch the surface of the AC servo motor, servo drive or regenerative resistor which will be hot while operating.



**⚠ CAUTION**

**Risk of physical damage to watches and magnetic storage media.**



- ◆ Strong magnetic force may destroy watches and magnetizable data storage media near the AC servo motor!
- ◆ Do not bring watches or magnetizable data storage media in the vicinity (<300 mm) of the AC servo motor!

## 2.3 Reasonably foreseeable misuse

**⚠ WARNING**



**Risk of damage to property.**

AC servo motors must not be operated:

- (1) Outdoors.
- (2) In potentially explosive atmospheres.

## 2.4 Conversions and modifications

**⚠ WARNING**



**Risk of personal injury or damage to property.**

- ◆ Conversions or modifications to AC servo motor are prohibited.

Modifications of AC servo motor are not permitted. Please contact HIWIN MIKROSYSTEM for special request.

## 2.5 Residual risks

**⚠ CAUTION**



**Personal injury or damage to property.**

- ◆ During normal operation, there are no residual risks associated with AC servo motor components. Warnings about risks that may arise during commissioning, maintenance and repair work are provided in the relevant sections.

## 2.6 Personnel requirements

- Operation staff are trained in the safe operation practices for AC servo motor systems and have fully read and understood this user manual.
- Maintenance staff maintain and repair AC servo motor systems in such a way that they pose no danger to people, property or the environment.
- Qualified personnel are those who, based on their training and experience, are capable of identifying risks and avoiding potential hazards when working with these products.

### CAUTION

- ◆ Only authorized and competent ones may carry out work on AC servo motor components. They must be familiar with the safety equipment and regulations before starting work.

Table 2.6.1

Activity	Qualification
Commissioning	Trained specialist personnel of the dealer or manufacturer
Normal Operation	Trained personnel
Cleaning	Trained personnel
Maintenance	Trained specialist personnel of the dealer or manufacturer
Repairs	Trained specialist personnel of the dealer or manufacturer

## 2.7 Protective equipment

Possible safety equipment/measures:

- Personal protective equipment in accordance with regional regulations.
- Zero-contact protective equipment.
- Mechanical protective equipment.

## 2.8 Labels on servo motor

### ■ Nameplate



Figure 2.8.1

### ■ Location of safety symbols on motor

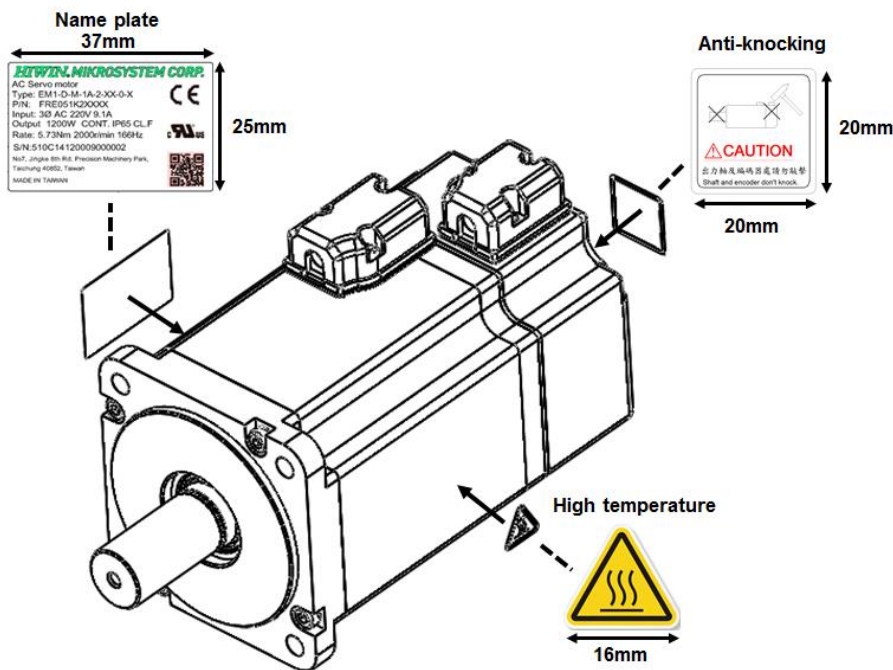

Figure 2.8.2

(This page is intentionally left blank.)

## 3. Product description

3.	Product description .....	3-1
3.1	Servo motor description.....	3-2
3.2	Main components of servo motor .....	3-3
3.3	Order code .....	3-4
3.3.1	Model explanations .....	3-4
3.3.1.1	E series AC servo motor.....	3-4
3.3.1.2	E1 Series Servo Drive .....	3-5
3.3.1.3	E2 Series Servo Drive .....	3-7
3.3.1.4	Power cable.....	3-8
3.3.1.5	Encoder cable .....	3-9
3.3.1.6	Combination of E series AC servo motor, servo drives and cable .....	3-10
3.3.2	Technical data .....	3-12
3.3.2.1	EM1-C-M-05-2-□-□-0-□-technical data .....	3-12
3.3.2.2	EM1-C-M-10-2-□-□-0-□-technical data .....	3-13
3.3.2.3	EM1-C-M-20-2-□-□-0-□-technical data .....	3-14
3.3.2.4	EM1-C-M-40-2-□-□-0-□-technical data .....	3-15
3.3.2.5	EM1-C-M-75-2-□-□-0-□-technical data .....	3-16
3.3.2.6	EM1-A-M-1K-2-□-□-0-□-technical data.....	3-17
3.3.2.7	EM1-D-M-1A-2-□-□-0-□-technical data .....	3-18
3.3.2.8	EM1-D-M-2K-2-□-□-0-□-technical data .....	3-19
3.3.3	Mechanical overview.....	3-21
3.3.4	Selection calculation .....	3-24
3.3.4.1	Mechanical mechanism.....	3-24
3.3.4.2	Motion profile .....	3-26
3.3.4.3	Load inertia calculation.....	3-27
3.3.4.4	Motor speed calculation .....	3-28
3.3.4.5	Motor torque calculation .....	3-29
3.3.4.6	Regenerative energy calculation .....	3-31
3.3.5	Operating instructions .....	3-33
3.3.6	De-rating curve.....	3-34

### 3.1 Servo motor description

AC servo motor is a high speed and low torque motor. It can control rotating motor, and control the current, speed, and position through the servo drive. It has the characteristics of high precision, low noise, high response, and high instantaneous output.

New developed AC servo motor can be applicable to FPD, semiconductor, laser cutting, PCB, machine tool, 3C electronics, energy, automobile, measuring/inspection industry, and related automation industry. Compared with the last generation of FR series, EM1 servo motor enhances maximum speed, encoder resolution, compact size, and ensure speedy settling, stability, tuneless function with dynamic payload by working with brand-new E series servo drive, that can effectively improve production efficiency.

- 50 W ~ 750 W AC servo motor appearance is shown as below:

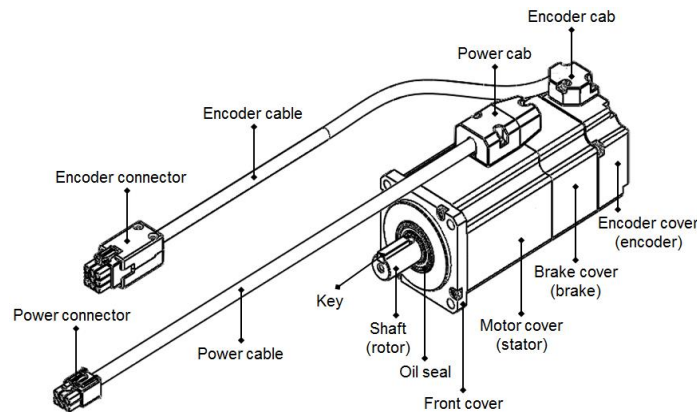

Figure 3.1.1

- 1 kW ~ 2 kW AC servo motor appearance is shown as below:

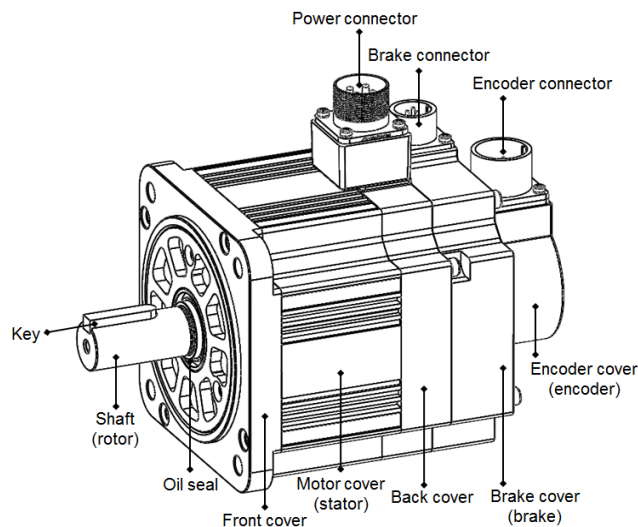

Figure 3.1.2

### 3.2 Main components of servo motor

Table 3.2.1 Combination of HIWIN AC servo motors and servo drives

Servo Motor Model	Rated Output	Rated Torque	Rated Speed	Servo Drive Model
EM1-C-M-05-2-□-□-0-□	50 W	0.16N m	3,000 rpm	ED1□-□□-0422-A□ ED2□-□□-003-1-A-□□
EM1-C-M-10-2-□-□-0-□	100 W	0.32N m	3,000 rpm	ED1□-□□-0422-A□ ED2□-□□-003-1-A-□□
EM1-C-M-20-2-□-□-0-□	200 W	0.64N m	3,000 rpm	ED1□-□□-0422-A□ ED2□-□□-003-1-A-□□
EM1-C-M-40-2-□-□-0-□	400 W	1.27N m	3,000 rpm	ED1□-□□-0422-A□ ED2□-□□-003-1-A-□□
EM1-C-M-75-2-□-□-0-□	750 W	2.39N m	3,000 rpm	ED1□-□□-1022-A□ ED2□-□□-006-1-A-□□
EM1-A-M-1K-2-□-□-0-□	1 kW	4.77N m	2,000 rpm	ED1□-□□-1022-A□ ED2□-□□-006-1-A-□□
EM1-D-M-1A-2-□-□-0-□	1.2 kW	5.73N m	2,000 rpm	ED1□-□□-2032-A□ ED2□-□□-009-1-A-□□
EM1-D-M-2K-2-□-□-0-□	2 kW	9.55N m	2,000 rpm	ED1□-□□-2032-A□

## 3.3 Order code

### 3.3.1 Model explanations

#### 3.3.1.1 E series AC servo motor

For further use with drives, cable, and accessory, please refer to chapter 5 and 11.

Table 3.3.1.1.1 AC servo motor model explanation

Code	1	2	3	-	4	-	5	-	6	7	-	8	-	9	-	10	-	11	-	12
Example	E	M	1	-	C	-	M	-	0	5	-	2	-	B	-	E	-	0	-	A
1, 2, 3: E Series Servo Motor	EM1																			
4: Rated/ Max. speed	A = 2000 / 3000 rpm C = 3000 / 6000 rpm D = 2000 / 5000 rpm																			
5: Rotor inertia	M = Medium inertia																			
6, 7: Rated output	05 = 50 W 10 = 100 W 20 = 200 W 40 = 400 W 75 = 750 W 1K = 1000 W 1A = 1200 W 2K = 2000 W																			
8: Input voltage	2 = 220 VAC																			
9: Brake option	0 = Without brake B = With brake																			
10: Encoder option	C = 17 bit magnetic incremental (battery is not required) D = 17 bit single-turn /16 bit multi-turn magnetic absolute (battery is required) E = 23 bit incremental (battery is not required) F = 23 bit single-turn /16 bit multi-turn absolute (battery is required)																			
11: Standard/ Customized	0 = Standard 1 = Customized																			
12: Shaft type	A = Round shaft / without oil seal B = Round shaft / with oil seal C = Shaft with key / without oil seal D = Shaft with key / with oil seal																			





## Note:

- (1) Servo drive model no. 12 digits (ED1□-□□-□□□□-□0): STO function without security approval.
- (2) Servo drive model no. 14 digits (ED1□-□□-□□□□-□1-□□): STO function with security approval.
- (3) For the communication settings and details about fieldbus servo drive (ED1F-E), please refer to “E1 Series Servo Drive EtherCAT (CoE) Communications Command Manual.”
- (4) For the communication settings and details about fieldbus servo drive (ED1F-L), please refer to “E1 Series Servo Drive MECHATROLINK-III Communication Command Manual.”
- (5) For the settings and details about gantry function servo drive (ED1□-□G), please refer to “E1 Series Servo Drive Gantry Control System User Manual.”
- (6) When the 10th digit of the model number is 2 and the AC voltage is 100 ~ 120 Vac, only single-phase input power can be used.
- (7) 400 V servo drives (ED1□-□□-□□□3) and gantry function servo drives (ED1□-□G) only support Thunder 1.6.11.0 or later versions.
- (8) If the 10<sup>th</sup> digit = 2, the following drives are supported: 400 W / 500 W / 1 kW / 1.2 kW / 2 kW / 4 kW. If the 10<sup>th</sup> digit = 3, the following drives are supported: 5 kW / 7.5 kW.
- (9) CoE is the acronym for “CANopen over EtherCAT”; MoE is the acronym for “mega-ulink over EtherCAT.”
- (10) When using API/MPI library with servo drive, users should carefully read through “API/MPI Library Reference Manual” to check if Windows system is supported.
- (11) ED1□-□□-□□□□-T1-□□ is a GT servo drive, its functions are as follows:
  1. Support nano precision function.
  2. Support 2D Error map (with ED1□-□G-□□□□-T1-□□). Gantry function cannot be used while users enable 2D Error map.
  3. Support DC 96-120V.

### 3.3.1.3 E2 Series Servo Drive

For detailed functions of E2 series servo drive, please refer to “E2 Series Servo Drive User Manual.”

Table 3.3.1.3.1 E2 series servo drive model explanation

Code	1	2	3	4	-	5	6	-	7	8	9	-	10	-	11	-	12	13
Example	E	D	2	S	-	V	0	-	0	0	3	-	1	-	C	-	0	0
1, 2, 3: E2 Series Servo Drive	ED2																	
4: Type	S = Standard									F = Fieldbus								
5, 6: Control Interface	V0 = Voltage command and pulse									E0 = EtherCAT (CoE) H3 = mega-ulink (with HIWIN MoE HIMC motion controller or API/MPI motion control command library)								
7, 8, 9: Rated Output	003 = 3 Arms 006 = 6.3 Arms 009 = 9.4 Arms																	
10: AC Phase Input	1 = Single/Three-phase 100~240 Vac (Rated 003, 006, 009) 2 = Three-phase 200~240 Vac (Not supported yet) 3 = Three-phase 380~480 Vac (Not supported yet)																	
11: Function	A = AC B = Basic C = Advanced T = GT																	
12, 13: Reserved	Reserved																	

Note:

- (1) CoE is the acronym for “CANopen over EtherCAT”; MoE is the acronym for “mega-ulink over EtherCAT.”
- (2) When using API/MPI library with servo drive, users should carefully read through “API/MPI Library Reference Manual” to check if Windows system is supported.

**3.3.1.4 Power cable**

For combination of E series AC servo motors and servo drives, please refer to section 3.3.5.

Table 3.3.1.4.1

Code	1	2	3	4	-	5	6	-	7	8	-	9	10	11	-	12
Example	H	V	P	S	-	0	4	-	A	B	-	0	3	M	-	B
1, 2, 3: series name	HVP															
4: Capacity	S = Small capacity (50 W-750 W)									M = Medium capacity (1 kW-2 kW)						
5, 6: Pin assignment	04 = U / V / W / GND									06 = U / V / W / GND / B+ / B-						
7: Motor connector	A = AMP connector B = Straight military type connector C = L shape military type connector															
8: Drive connector	A = European type terminal (with ED2 drive) B = R type terminal (with ED1 drive)															
9, 10, 11: Cable length	03M = 3M 05M = 5M 07M = 7M 10M = 10M 15M = 15M															
12: Cable type	B = Flexible type															

Note:

- (1) Cable length should not be more than 30M.
- (2) Cable length can be customized for integer such as 1M, 2M, 3M...30M.
- (3) Information about pin assignment and connector specification can be referred to section 5.2.1.
- (4) Information about bending radius limitation of power cable can be referred to section 5.2.1.4.

### 3.3.1.5 Encoder cable

For combination of servo motors and servo drives, please refer to section 3.3.5.

Table 3.3.1.5.1

Code	1	2	3	-	4	5	6	-	7	8	-	9	10	11	-	12
Example	H	V	E	-	2	3	A	-	A	B	-	0	3	M	-	B
1, 2, 3: series name	HVE															
4, 5, 6: Encoder type	23A = 23 bit absolute encoder								23I = 23 bit incremental encoder							
7: Motor connector	A = AMP connector B = Straight military type connector C = L shape military type connector															
8: Drive connector	B = 3M SCR type connector															
9, 10, 11: Cable length	03M = 3M 05M = 5M 07M = 7M 10M = 10M 15M = 15M															
12: Cable type	B = Reserved															

Note:

- (1) Cable length should not be more than 30M.
- (2) Cable length can be customized for integer such as 1M, 2M, 3M...30M.
- (3) Information about pin assignment and connector specification can be referred to section 5.2.1.
- (4) Information about bending radius limitation of power cable can be referred to section 5.2.1.4.

**3.3.1.6 Combination of E series AC servo motor, servo drives and cable**

Table 3.3.1.6.1 E1 series servo drive and motor combination

AC servo motor	Capacity	Power cable	Encoder cable	Servo drive
EM1CM0520E0□	50 W	HVPS04AB□□MB	HVE23IAB□□MB	ED1□-□□-0422-A□
EM1CM052BE0□		HVPS06AB□□MB		
EM1CM0520F0□		HVPS04AB□□MB	HVE23AAB□□MB	
EM1CM052BF0□		HVPS06AB□□MB		
EM1CM1020E0□	100 W	HVPS04AB□□MB	HVE23IAB□□MB	
EM1CM102BE0□		HVPS06AB□□MB		
EM1CM1020F0□		HVPS04AB□□MB	HVE23AAB□□MB	
EM1CM102BF0□		HVPS06AB□□MB		
EM1CM2020E0□	200 W	HVPS04AB□□MB	HVE23IAB□□MB	
EM1CM202BE0□		HVPS06AB□□MB		
EM1CM2020F0□		HVPS04AB□□MB	HVE23AAB□□MB	
EM1CM202BF0□		HVPS06AB□□MB		
EM1CM4020E0□	400 W	HVPS04AB□□MB	HVE23IAB□□MB	
EM1CM402BE0□		HVPS06AB□□MB		
EM1CM4020F0□		HVPS04AB□□MB	HVE23AAB□□MB	
EM1CM402BF0□		HVPS06AB□□MB		
EM1CM7520E0□	750 W	HVPS04AB□□MB	HVE23IAB□□MB	
EM1CM752BE0□		HVPS06AB□□MB		
EM1CM7520F0□		HVPS04AB□□MB	HVE23AAB□□MB	
EM1CM752BF0□		HVPS06AB□□MB		
EM1AM1K20E0□	1 kW	HVPM04□B□□MB	HVE23I□B□□MB	
EM1AM1K2BE0□		HVPM06□B□□MB		
EM1AM1K20F0□		HVPM04□B□□MB	HVE23A□B□□MB	
EM1AM1K2BF0□		HVPM06□B□□MB		
EM1DM1A20E0□	1.2 kW	HVPM04□B□□MB	HVE23I□B□□MB	
EM1DM1A2BE0□		HVPM06□B□□MB		
EM1DM1A20F0□		HVPM04□B□□MB	HVE23A□B□□MB	
EM1DM1A2BF0□		HVPM06□B□□MB		
EM1DM2K20E0□	2 kW	HVPM04□B□□MB	HVE23I□B□□MB	
EM1DM2K2BE0□		HVPM06□B□□MB		
EM1DM2K20F0□		HVPM04□B□□MB	HVE23A□B□□MB	
EM1DM2K2BF0□		HVPM06□B□□MB		

Table 3.3.1.6.2 E2 series servo drive and motor combination

AC servo motor	Capacity	Power cable	Encoder cable	Servo drive
EM1CM0520C0□	50 W	HVPS04AA□□MB	HVE23IAB□□MB	ED2□-□□-003-1-A-00
EM1CM052BC0□		HVPS06AA□□MB		
EM1CM0520D0□		HVPS04AA□□MB	HVE23AAB□□MB	
EM1CM052BD0□		HVPS06AA□□MB		
EM1CM1020C0□	100 W	HVPS04AA□□MB	HVE23IAB□□MB	
EM1CM102BC0□		HVPS06AA□□MB		
EM1CM1020D0□		HVPS04AA□□MB	HVE23AAB□□MB	
EM1CM102BD0□		HVPS06AA□□MB		
EM1CM2020C0□	200 W	HVPS04AA□□MB	HVE23IAB□□MB	
EM1CM202BC0□		HVPS06AA□□MB		
EM1CM2020D0□		HVPS04AA□□MB	HVE23AAB□□MB	
EM1CM202BD0□		HVPS06AA□□MB		
EM1CM4020C0□	400 W	HVPS04AA□□MB	HVE23IAB□□MB	
EM1CM402BC0□		HVPS06AA□□MB		
EM1CM4020D0□		HVPS04AA□□MB	HVE23AAB□□MB	
EM1CM402BD0□		HVPS06AA□□MB		
EM1CM7520C0□	750 W	HVPS04AA□□MB	HVE23IAB□□MB	ED2□-□□-006-1-A-00
EM1CM752BC0□		HVPS06AA□□MB		
EM1CM7520D0□		HVPS04AA□□MB	HVE23AAB□□MB	
EM1CM752BD0□		HVPS06AA□□MB		
EM1AM1K20C0□	1 kW	HVPM04□A□□MB	HVE23I□B□□MB	
EM1AM1K2BC0□		HVPM06□A□□MB		
EM1AM1K20D0□		HVPM04□A□□MB	HVE23A□B□□MB	
EM1AM1K2BD0□		HVPM06□A□□MB		
EM1DM1A20C0□	1.2 kW	HVPM04□A□□MB	HVE23I□B□□MB	ED2□-□□-009-1-A-00
EM1DM1A2BC0□		HVPM06□A□□MB		
EM1DM1A20D0□		HVPM04□A□□MB	HVE23A□B□□MB	
EM1DM1A2BD0□		HVPM06□A□□MB		

### 3.3.2 Technical data

#### 3.3.2.1 EM1-C-M-05-2-□-□-0-□-technical data

Table 3.3.2.1.1 EM1-C-M-05-2-□-□-0-□ data sheet

Motor parameter	Symbol	Unit	EM1-C-M-05-2-□-□-0-□
<b>Electrical data</b>			
Drive input voltage	V	V	AC 220
Output power	P	W	50
Rated torque	Tc	N·m	0.16
Rated current	Ic	Arms	0.64
Maximum torque	Tp	N·m	0.59
Maximum current	Ip	Arms	2.8
Rated speed	$\omega_c$	rpm	3000
Maximum speed	$\omega_p$	rpm	6000
Torque constant	Kt	N·m/Arms	0.25
Voltage constant (back EMF constant)	Ke	V/krpm	18.526
Winding resistance	R	$\Omega$	25.24
Winding inductivity	L	mH	13.09
<b>Mechanical data</b>			
Moment of inertia of the rotor	J	kg·m <sup>2</sup> (x10 <sup>-4</sup> )	0.0368(0.0401)
Weight	M	kg	0.36(0.56)
Insulation class	-	-	Class F
Degree of protection	-	-	*IP 65
<b>Brake data</b>			
Static friction torque	Tb	N·m	0.32
Brake rated current	Ib	A	0.25
Brake input voltage	Vb	V	DC 24±10%
Braking time	To	ms	40
Release time	Tr	ms	20

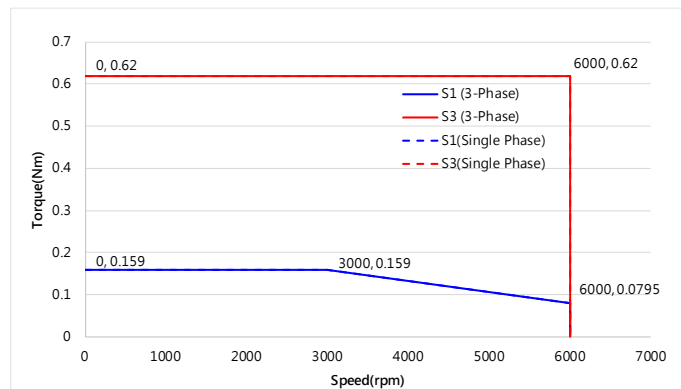

Figure 3.3.2.1.1



**3.3.2.2 EM1-C-M-10-2-□-□-0-□-technical data**

Table 3.3.2.2.1 EM1-C-M-10-2-□-□-0-□ data sheet

Motor parameter	Symbol	Unit	EM1-C-M-10-2-□-□-0-□
<b>Electrical data</b>			
Drive input voltage	V	V	AC 220
Output power	P	W	100
Rated torque	Tc	N·m	0.32
Rated current	Ic	Arms	0.78
Maximum torque	Tp	N·m	1.18
Maximum current	Ip	Arms	3.45
Rated speed	$\omega_c$	rpm	3000
Maximum speed	$\omega_p$	rpm	6000
Torque constant	Kt	N·m/Arms	0.41
Voltage constant (back EMF constant)	Ke	V/krpm	28.364
Winding resistance	R	$\Omega$	22.72
Winding inductivity	L	mH	13.86
<b>Mechanical data</b>			
Moment of inertia of the rotor	J	kg·m <sup>2</sup> (x10 <sup>-4</sup> )	0.0620(0.0653)
Weight	M	kg	0.47(0.67)
Insulation class	-	-	Class F
Degree of protection	-	-	*IP 65
<b>Brake data</b>			
Static friction torque	Tb	N·m	0.32
Brake rated current	Ib	A	0.25
Brake input voltage	Vb	V	DC 24±10%
Braking time	To	ms	40
Release time	Tr	ms	20

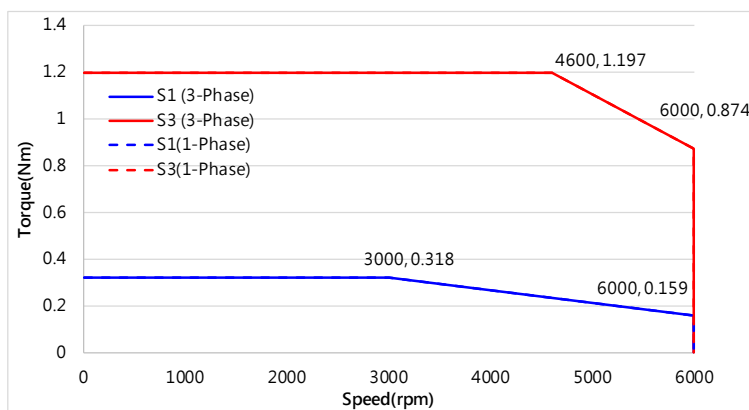

Figure 3.3.2.2.1

**3.3.2.3 EM1-C-M-20-2-□-□-0-□-technical data**

Table 3.3.2.3.1 EM1-C-M-20-2-□-□-0-□ data sheet

Motor parameter	Symbol	Unit	EM1-C-M-20-2-□-□-0-□
<b>Electrical data</b>			
Drive input voltage	V	V	AC 220
Output power	P	W	200
Rated torque	Tc	N·m	0.64
Rated current	Ic	Arms	1.6
Maximum torque	Tp	N·m	2.24
Maximum current	Ip	Arms	6.4
Rated speed	$\omega_c$	rpm	3000
Maximum speed	$\omega_p$	rpm	6000
Torque constant	Kt	N·m/Arms	0.4
Voltage constant (back EMF constant)	Ke	V/krpm	27.23
Winding resistance	R	$\Omega$	5.53
Winding inductivity	L	mH	8.76
<b>Mechanical data</b>			
Moment of inertia of the rotor	J	kg·m <sup>2</sup> (x10 <sup>-4</sup> )	0.263(0.326)
Weight	M	kg	0.851(1.085)
Insulation class	-	-	Class F
Degree of protection	-	-	*IP 65
<b>Brake data</b>			
Static friction torque	Tb	N·m	1.3
Brake rated current	Ib	A	0.32
Brake input voltage	Vb	V	DC 24±10%
Braking time	To	ms	30
Release time	Tr	ms	20

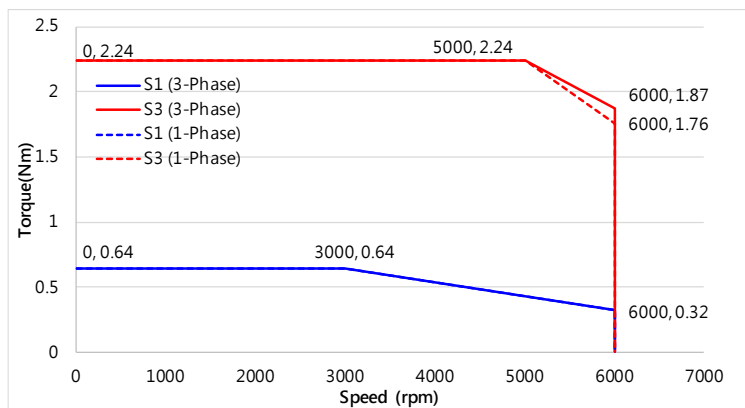

Figure 3.3.2.3.1

**3.3.2.4 EM1-C-M-40-2-□-□-0-□-technical data**

Table 3.3.2.4.1 EM1-C-M-40-2-□-□-0-□ data sheet

Motor parameter	Symbol	Unit	EM1-C-M-40-2-□-□-0-□
<b>Electrical data</b>			
Drive input voltage	V	V	AC 220
Output power	P	W	400
Rated torque	Tc	N·m	1.27
Rated current	Ic	Arms	2.5
Maximum torque	Tp	N·m	4.44
Maximum current	Ip	Arms	10
Rated speed	$\omega_c$	rpm	3000
Maximum speed	$\omega_p$	rpm	6000
Torque constant	Kt	N·m/Arms	0.508
Voltage constant (back EMF constant)	Ke	V/krpm	33.87
Winding resistance	R	$\Omega$	3.59
Winding inductivity	L	mH	7.22
<b>Mechanical data</b>			
Moment of inertia of the rotor	J	kg·m <sup>2</sup> (x10 <sup>-4</sup> )	0.48(0.49)
Weight	M	kg	1.25(1.8)
Insulation class	-	-	Class F
Degree of protection	-	-	*IP 65
<b>Brake data</b>			
Static friction torque	Tb	N·m	1.3
Brake rated current	Ib	A	0.32
Brake input voltage	Vb	V	DC 24±10%
Braking time	To	ms	30
Release time	Tr	ms	20

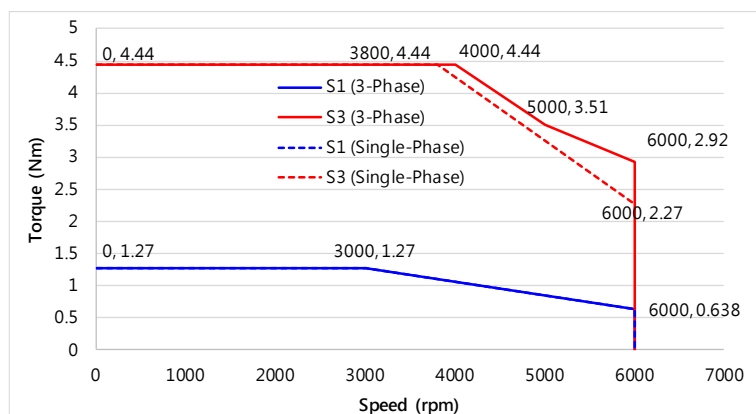

Figure 3.3.2.4.1

**3.3.2.5 EM1-C-M-75-2-□-□-0-□-technical data**

Table 3.3.2.5.1 EM1-C-M-75-2-□-□-0-□ data sheet

Motor parameter	Symbol	Unit	EM1-C-M-75-2-□-□-0-□
<b>Electrical data</b>			
Drive input voltage	V	V	AC 220
Output power	P	W	750
Rated torque	Tc	N·m	2.39
Rated current	Ic	Arms	4.65
Maximum torque	Tp	N·m	8.36
Maximum current	Ip	Arms	18.6
Rated speed	ωc	rpm	3000
Maximum speed	ωp	rpm	6000
Torque constant	Kt	N·m/Arms	0.514
Voltage constant (back EMF constant)	Ke	V/krpm	33.48
Winding resistance	R	Ω	1.08
Winding inductivity	L	mH	4.6
<b>Mechanical data</b>			
Moment of inertia of the rotor	J	kg·m <sup>2</sup> (x10 <sup>-4</sup> )	1.44(1.47)
Weight	M	kg	2.7(3.36)
Insulation class	-	-	Class F
Degree of protection	-	-	*IP 65
<b>Brake data</b>			
Static friction torque	Tb	N·m	2.4
Brake rated current	Ib	A	0.358
Brake input voltage	Vb	V	DC 24±10%
Braking time	To	ms	45
Release time	Tr	ms	10

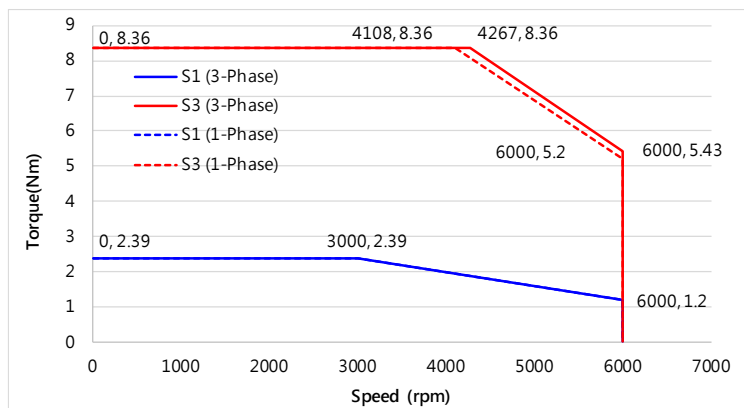

Figure 3.3.2.5.1

**3.3.2.6 EM1-A-M-1K-2-□-□-0-□-technical data**

Table 3.3.2.6.1 EM1-A-M-1K-2-□-□-0-□ data sheet

Motor parameter	Symbol	Unit	EM1-A-M-1K-2-□-□-0-□
<b>Electrical data</b>			
Drive input voltage	V	V	AC 220
Output power	P	W	1000
Rated torque	Tc	N·m	4.77
Rated current	Ic	Arms	5.1
Maximum torque	Tp	N·m	14.3
Maximum current	Ip	Arms	15.3
Rated speed	$\omega_c$	rpm	2000
Maximum speed	$\omega_p$	rpm	3000
Torque constant	Kt	N·m/Arms	0.935
Voltage constant (back EMF constant)	Ke	V/krpm	54.15
Winding resistance	R	$\Omega$	0.81
Winding inductivity	L	mH	8
<b>Mechanical data</b>			
Moment of inertia of the rotor	J	kg·m <sup>2</sup> (x10 <sup>-4</sup> )	7.2(8.0)
Weight	M	kg	5.4(6.2)
Insulation class	-	-	Class F
Degree of protection	-	-	*IP 65
<b>Brake data</b>			
Static friction torque	Tb	N·m	10
Brake rated current	Ib	A	0.56
Brake input voltage	Vb	V	DC 24±10%
Braking time	To	ms	80
Release time	Tr	ms	30

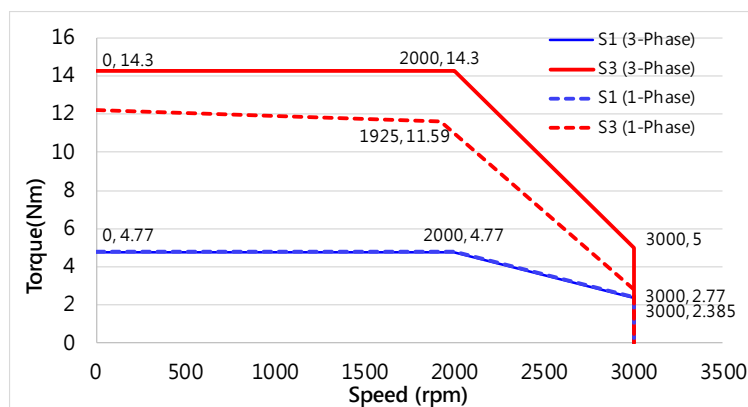

Figure 3.3.2.6.1

**3.3.2.7 EM1-D-M-1A-2-□-□-0-□-technical data**

Table 3.3.2.7.1 EM1-D-M-1A-2-□-□-0-□ data sheet

Motor parameter	Symbol	Unit	EM1-D-M-1A-2-□-□-0-□
<b>Electrical data</b>			
Drive input voltage	V	V	AC 220
Output power	P	W	1200
Rated torque	Tc	N·m	5.73
Rated current	Ic	Arms	9.1
Maximum torque	Tp	N·m	16
Maximum current	Ip	Arms	27
Rated speed	ωc	rpm	2000
Maximum speed	ωp	rpm	5000
Torque constant	Kt	N·m/Arms	0.63
Voltage constant (back EMF constant)	Ke	V/krpm	41.52
Winding resistance	R	Ω	0.482
Winding inductivity	L	mH	4.54
<b>Mechanical data</b>			
Moment of inertia of the rotor	J	kg·m <sup>2</sup> (x10 <sup>-4</sup> )	7.2(8.0)
Weight	M	kg	5.3(6.1)
Insulation class	-	-	Class F
Degree of protection	-	-	*IP 65
<b>Brake data</b>			
Static friction torque	Tb	N·m	10
Brake rated current	Ib	A	0.56
Brake input voltage	Vb	V	DC 24±10%
Braking time	To	ms	80
Release time	Tr	ms	30

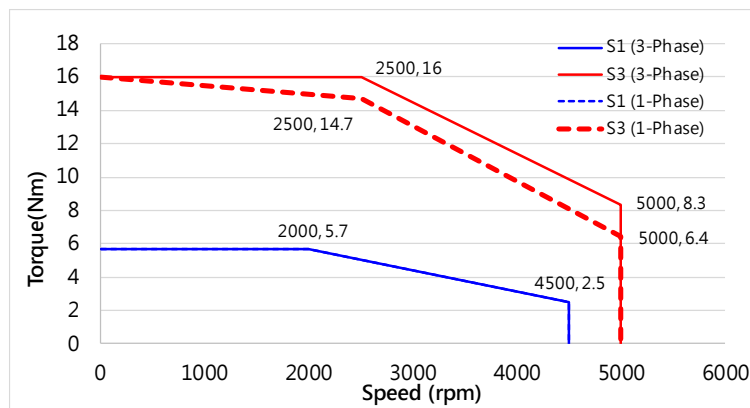

Figure 3.3.2.7.1

**3.3.2.8 EM1-D-M-2K-2-□-□-0-□-technical data**

Table 3.3.2.8.1 EM1-D-M-2K-2-□-□-0-□ data sheet

Motor parameter	Symbol	Unit	EM1-D-M-2K-2-□-□-0-□
<b>Electrical data</b>			
Drive input voltage	V	V	AC 220
Output power	P	W	2000
Rated torque	Tc	N·m	9.55
Rated current	Ic	Arms	12
Maximum torque	Tp	N·m	30
Maximum current	Ip	Arms	42
Rated speed	$\omega_c$	rpm	2000
Maximum speed	$\omega_p$	rpm	5000
Torque constant	Kt	N·m/Arms	0.796
Voltage constant (back EMF constant)	Ke	V/krpm	50.49
Winding resistance	R	$\Omega$	0.264
Winding inductivity	L	mH	2.825
<b>Mechanical data</b>			
Moment of inertia of the rotor	J	kg·m <sup>2</sup> (x10 <sup>-4</sup> )	12.8(13.3)
Weight	M	kg	7.9(8.7)
Insulation class	-	-	Class F
Degree of protection	-	-	*IP 65
<b>Brake data</b>			
Static friction torque	Tb	N·m	10
Brake rated current	Ib	A	0.56
Brake input voltage	Vb	V	DC 24±10%
Braking time	To	ms	80
Release time	Tr	ms	30

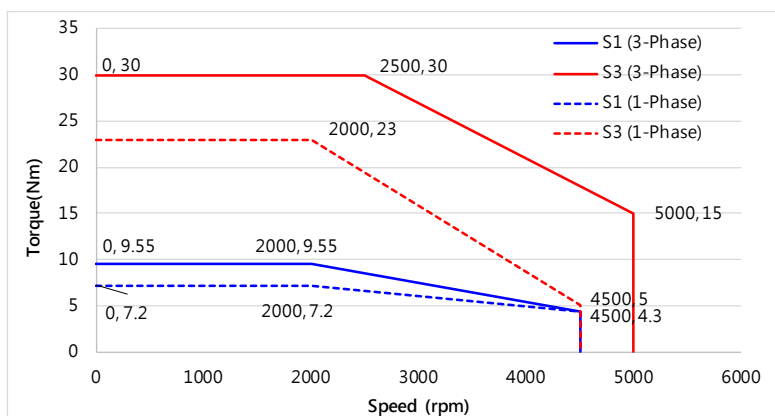

Figure 3.3.2.8.1

Note:

Note for section 3.3.2.1 to 3.3.2.8 are as follows:

- (1) Manufacturing tolerance :  $\pm 10\%$
- (2) (...) indicates motors with brakes.
- (3) \* indicates motor shaft and connector are not included.(If the motor shaft needs IP protection, oil seal is necessary).
- (4) The nominal motor properties are all single-phase/three-phase 220V input power. Please contact the sales representatives of HIWIN MIKROSYSTEM if you need 110V motor properties.



### 3.3.3 Mechanical overview

■ EM1-C-M-05-2-□-□-0-□

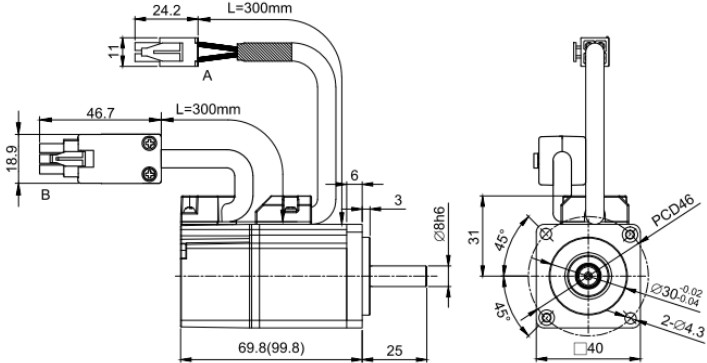

Figure 3.3.3.1

■ EM1-C-M-10-2-□-□-0-□

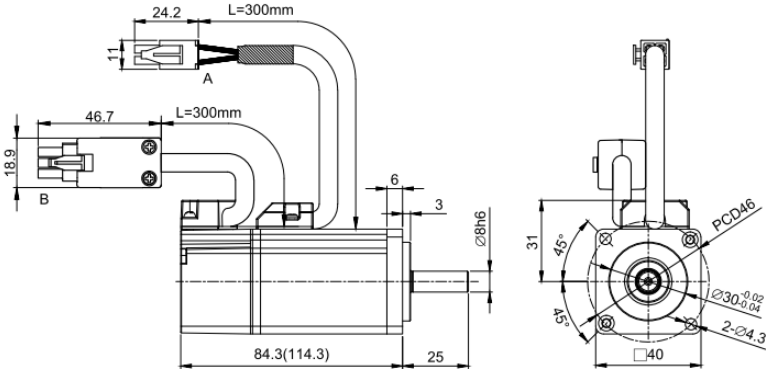

Figure 3.3.3.2

■ EM1-C-M-20-2-□-□-0-□

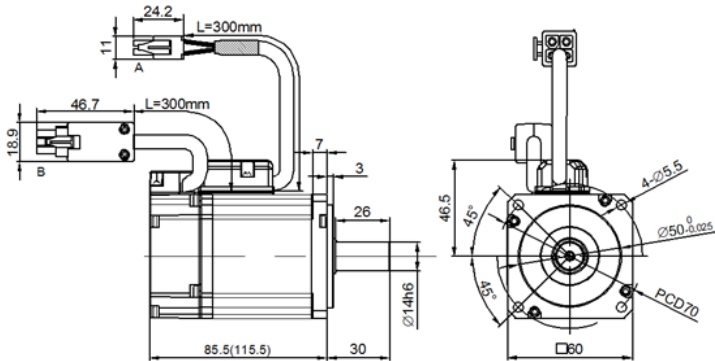

Figure 3.3.3.3

■ EM1-C-M-40-2-□-□-0-□

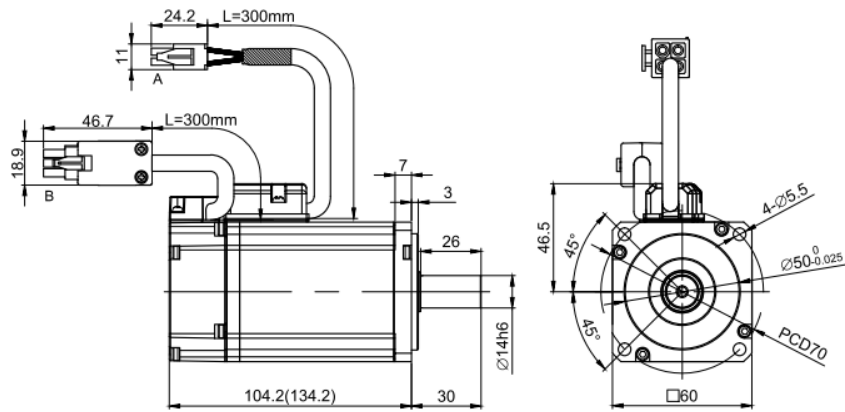

Figure 3.3.3.4

■ EM1-C-M-75-2-□-□-0-□

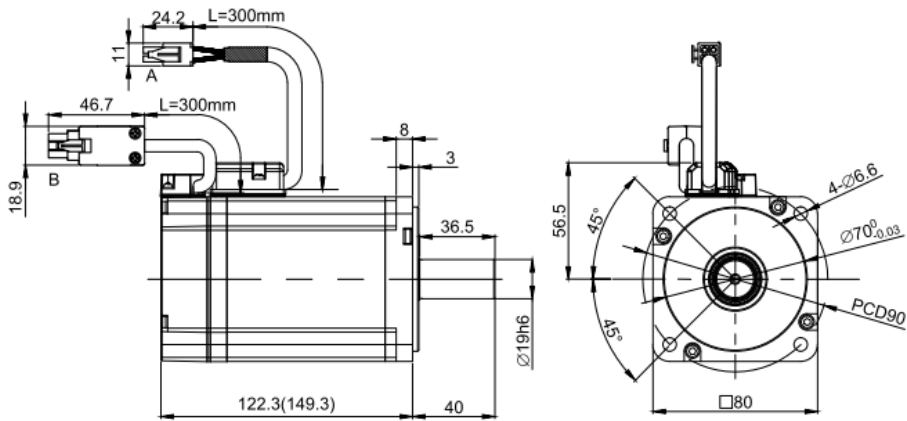

Figure 3.3.3.5

■ EM1-A-M-1K-2-□-□-0-□

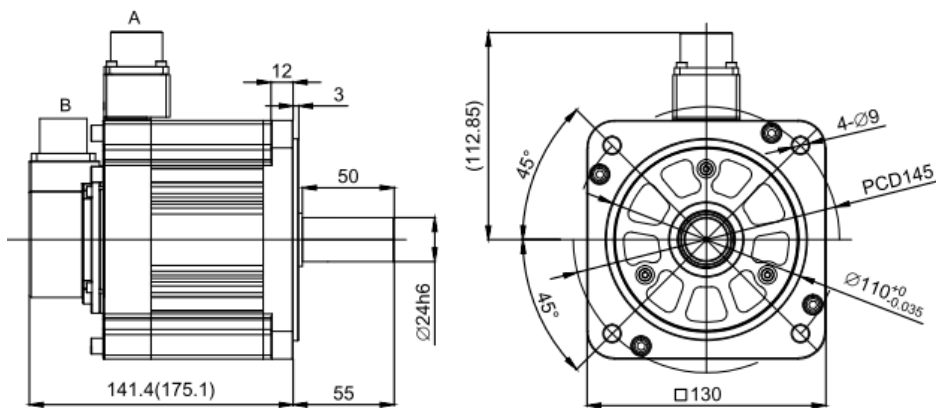

Figure 3.3.3.6

■ EM1-D-M-1A-2-□-□-0-□

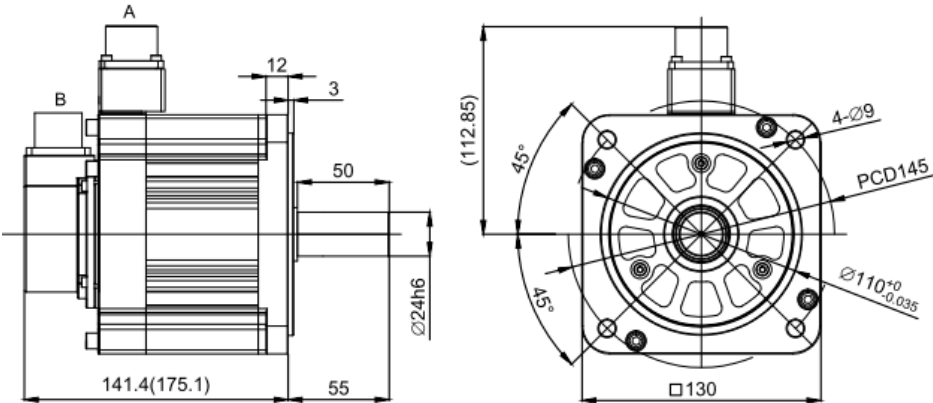

Figure 3.3.3.7

■ EM1-D-M-2K-2-□-□-0-□

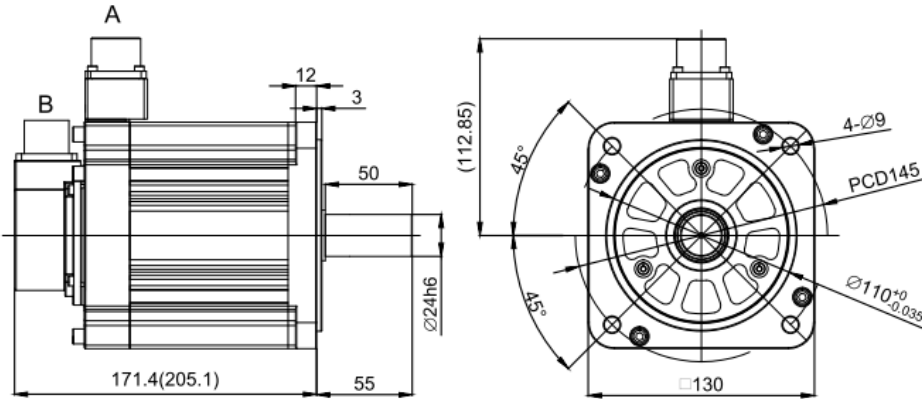

Figure 3.3.3.8

Note:

Motor shaft and connector are not included.(If the motor shaft needs IP protection, oil seal is necessary)

### 3.3.4 Selection calculation

#### 3.3.4.1 Mechanical mechanism

The way to select a suitable motor is based on speed, moving distance, and loading inertia as described in the following contents. The basic process for sizing a motor is as follows.

Step 1: Provide mechanical transmission mechanism.

Step 2: Provide motion profile.

Step 3: Provide load condition.

Step 4: Load inertia calculation.

Step 5: Motor speed calculation.

Step 6: Motor torque calculation.

Step 7: Motor sizing completed.

Table 3.3.4.1.1

$t_f$	Moving time (sec)	$J_B$	Ball screw inertia ( $kgm^2$ )
$t_a$	Acceleration time (sec)	$J_P$	Pulley inertia ( $kgm^2$ )
$t_d$	Deceleration time (sec)	$J_T$	Rotary table inertia ( $kgm^2$ )
$t_c$	Cycle time (sec)	$J_w$	Work pieces inertia ( $kgm^2$ )
$N$	Motor speed (rpm)	$J$	Total inertia ( $kgm^2$ )
$J_L$	Load inertia ( $kgm^2$ )	$D$	Outer diameter (m)
$J_r$	Rotor inertia ( $kgm^2$ )	$W$	Work piece weight (kg)
$T_p$	Peak torque (Nm)	$d$	Inner diameter (m)
$T_t$	Travelling torque (Nm)	$L$	Length (m)
$n$	Work pieces amount (pcs)	a, b, c	Side length (m)
$T_a$	Acceleration torque (Nm)	$T_d$	Deceleration torque (Nm)

There are many types of mechanical transmission, here we list three types of common transmission mechanism and requirements for motor sizing, as the table below:

Table 3.3.4.1.2

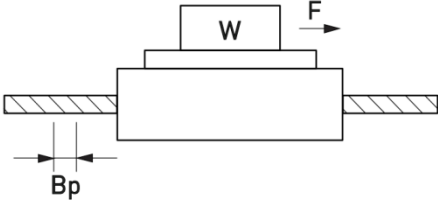
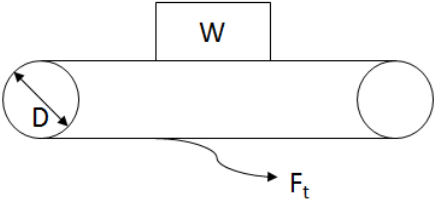
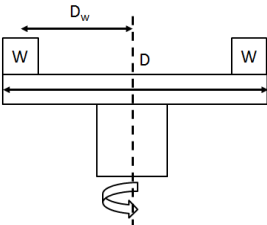
Transmission mechanism	Requirements
<p><b>Ball screw</b></p> 	<ul style="list-style-type: none"><li>◆ Installation direction: horizontal or vertical</li><li>◆ Ball screw diameter / length / lead</li><li>◆ Work pieces weight</li><li>◆ Outer force (F)</li></ul>
<p><b>Pulley &amp; Belt</b></p> 	<ul style="list-style-type: none"><li>◆ Installation direction: horizontal or vertical</li><li>◆ Pulley dimension / weight</li><li>◆ Work pieces weight / Belt weight</li><li>◆ Belt tension force (<math>F_t</math>)</li></ul>
<p><b>Rotary table</b></p> 	<ul style="list-style-type: none"><li>◆ Installation direction: horizontal or vertical</li><li>◆ Table dimension / weight</li><li>◆ Work pieces weight / quantities</li><li>◆ Distance from work pieces to rotation axis</li></ul>

### 3.3.4.2 Motion profile

#### ■ Trapezoidal profile

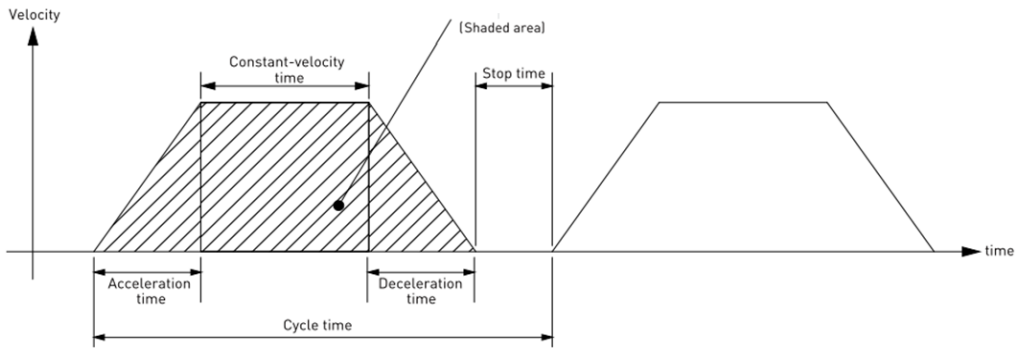

Figure 3.3.4.2.1

#### ■ Triangle profile

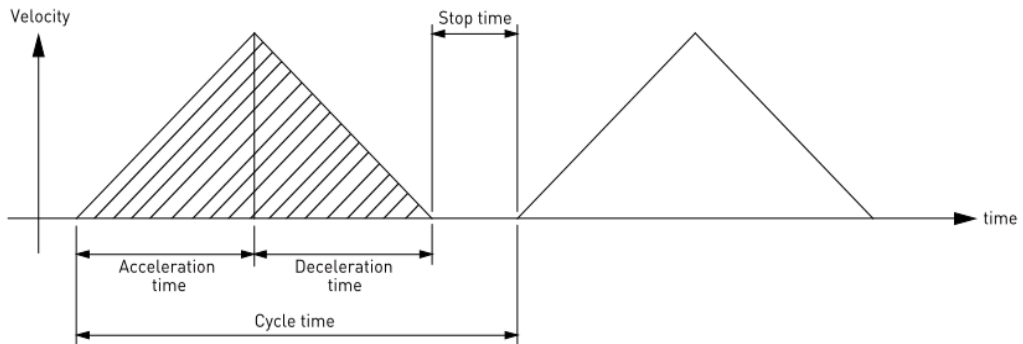
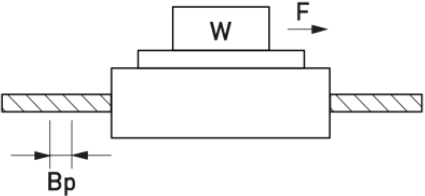
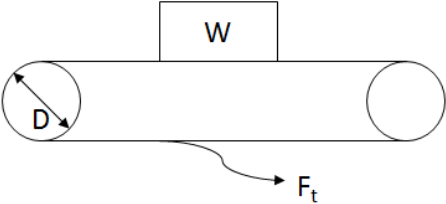
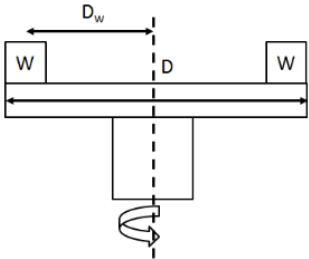

Figure 3.3.4.2.2

**3.3.4.3 Load inertia calculation**

Table 3.3.4.3.1

Transmission mechanism	Load inertia calculation
<p><b>Ball screw</b></p> 	$J_L = J_B + \frac{WB_p^2}{4\pi^2}$ <p><math>B_p</math> : Ball screw lead (m)</p>
<p><b>Pulley &amp; Belt</b></p> 	$J_L = J_P + \frac{W \times D^2}{4}$
<p><b>Rotary table</b></p> 	$J_L = J_T + n \times (J_w + WD_w^2)$

It is suggested to keep the load inertia ratio below 15 times of normal operation:

$$\text{Load inertia ratio} = \frac{(J_r + J_L)}{J_r} < 15$$

**3.3.4.4 Motor speed calculation**

Table 3.3.4.4.1

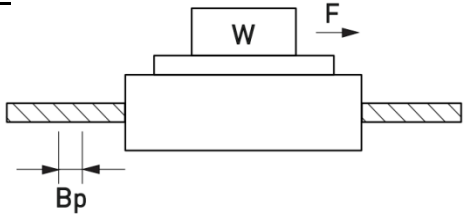
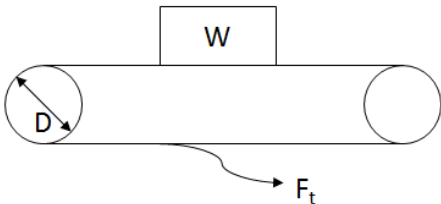
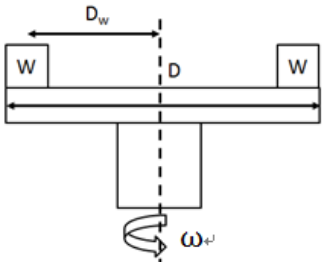
Transmission mechanism	Motor speed calculation
<p><b>Ball screw</b></p> 	$N = \frac{V}{B_p} \times 60 \quad V : \text{velocity} \left(\frac{m}{s}\right)$
<p><b>Pulley &amp; Belt</b></p> 	$N = \frac{V}{\pi D} \times 60 \quad V : \text{velocity} \left(\frac{m}{s}\right)$
<p><b>Rotary table</b></p> 	$N = \frac{\omega}{\pi} \times 30 \quad \omega : \text{angular velocity} \left(\frac{rad}{s}\right)$

- Motor calculation speed should be within motor continuous work range.

E.g., As the T-N curve shows below, 3000 rpm is the continuous work range of motor speed.

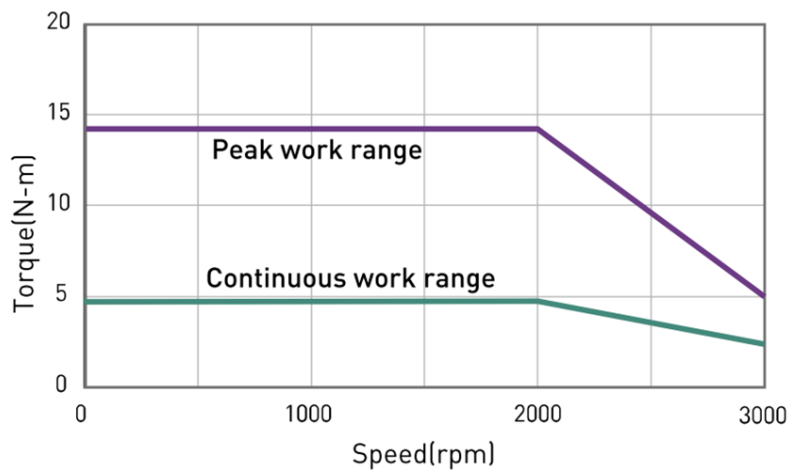
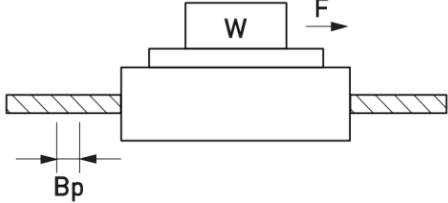
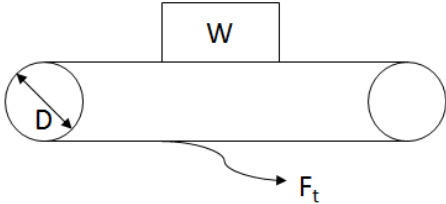
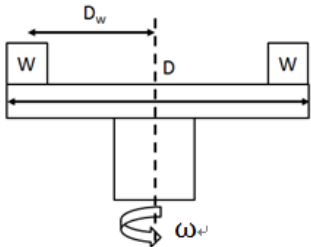

Figure 3.3.4.4.1



**3.3.4.5 Motor torque calculation**

Table 3.3.4.5.1

Transmission mechanism	Travelling torque calculation
<p><b>Ball screw</b></p> 	<ul style="list-style-type: none"> <li>◆ <math>T_t = \frac{B_p}{2\pi B_{eff}} \times (\mu g W + F)</math></li> <li>◆ <math>B_{eff}</math> : Ball screw efficiency (%)</li> <li>◆ <math>g</math> : gravity (<math>m/s^2</math>)</li> <li>◆ <math>\mu</math> : friction coefficient</li> </ul>
<p><b>Pulley &amp; Belt</b></p> 	<ul style="list-style-type: none"> <li>◆ <math>T_t = \frac{D}{2P_{eff}} \times (\mu g W + \mu g W_b + 2F_t)</math></li> <li>◆ <math>P_{eff}</math> : Pulley efficiency (%)</li> <li>◆ <math>F_t</math> : Belt tension force (N)</li> <li>◆ <math>W_b</math> : Belt weight (kg)</li> </ul>
<p><b>Rotary table</b></p> 	<ul style="list-style-type: none"> <li>◆ <math>T_t = \mu g W_T + n \times \mu g W</math></li> <li>◆ <math>W_T</math> : Rotary table weight (kg)</li> </ul>

<b>Acceleration torque</b>	$T_a = \frac{\pi N}{30t_a} \times (J_L + J_r) + T_f$
<b>Deceleration torque</b>	$T_a = \frac{\pi N}{30t_d} \times (J_L + J_r) - T_f$
<b>Equivalent torque</b>	$T_e = \sqrt{\frac{T_a^2 \times t_a + T_f^2 \times t_f + T_d^2 \times t_d}{t_c}}$ ; $c = t_a + t_f + t_d + t_s$ $t_s$ : stop time (sec)

- Its is suggested to keep motor calculation acceleration torque below 80% of motor peak torque.

***Acceleration torque < 0.8 × Motor peak torque***

- Its is suggested to keep motor calculation equivalent torque below 80% of motor rated torque.

***Equivalent torque < 0.8 × Motor rated torque***

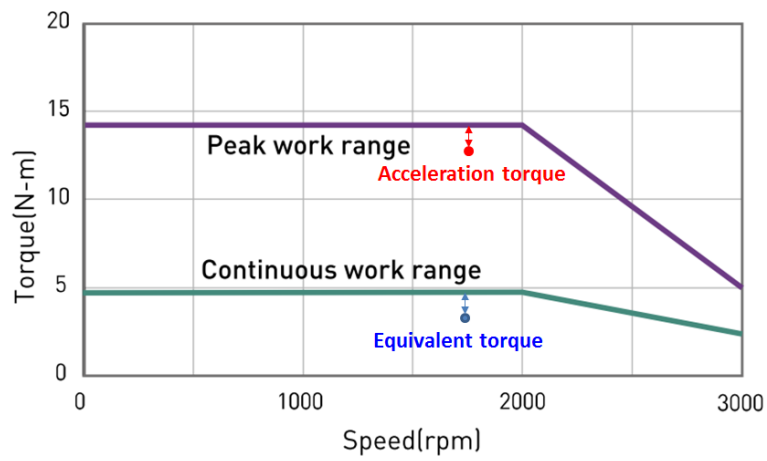

Figure 3.3.4.5.1

### 3.3.4.6 Regenerative energy calculation

The section mainly describe how to calculate the regenerative energy during operation, the procedure for regenerative energy are as follows.

- Step 1: Calculate rotation energy ( $E_s$ ) of Servo motor.

$$E_s = \frac{J_t n_m^2}{182}$$

- Step 2: Calculate energy ( $E_L$ ) consumed by load loss during deceleration period.

$$E_L = \frac{\pi \times n_m T_L t_D}{182} \text{ (if load loss is unknown, set } E_L = 0 \text{)}$$

- Step 3: Calculate energy ( $E_M$ ) consumed from Servo motor winding resistance.

$$E_M = \frac{3 \times I_M^2 \times R_M \times t_D}{2}$$

- Step 4: Calculate the energy that can be absorbed by Servo drive ( $E_D$ ).

$$E_D = \frac{C_{drive} \times (V_{gen}^2 - V_{main}^2)}{2 \times 10^6}$$

- Step 5: Calculate the energy for continuous period of regenerative operation ( $E_G$ ).

$$E_G = \frac{2\pi \times (n_m \times T_m \times t_m)}{60}$$

- Step 6: Calculate energy (capacity) consumed by the regenerative resistor (PR).

$$P_R = \frac{E_s - (E_L + E_M + E_D) + E_G}{t_c}$$

Table 3.3.4.6.1

Symbol	Unit	Description
$J_t$	kgm <sup>2</sup>	Total inertia (motor + load)
$n_m$	Rpm	Motor speed
$T_L$	Nm	Load torque
$t_D$	s	Deceleration time
$I_M$	Amp	Motor current during deceleration
$R_M$	Ohm	Motor resistance
$C_{drive}$	uF	Drive capacitance
$V_{gen}$	Vdc	Voltage at regeneration
$V_{main}$	Vdc	Voltage from DC bus
$T_m$	Nm	Motor torque during regeneration
$t_m$	s	Time during regeneration
$t_c$	s	Cycle time
$E_S, E_L, E_M, E_D, E_G$	Joule	-
$P_R$	Watt	-

### 3.3.5 Operating instructions

- Operating temperature: 0°C ~ 60°C (Derating is required at 40°C ~ 60°C to avoid condensation and icing).
- Operating humidity: 20% ~ 80% RH (Avoid condensation and icing).
- Vibration / Shock resistance: Less than 49 m/s<sup>2</sup> (In three direction: vertical, side to side, and front to back).
- Elevation: Less than 1000M (Derating is required at 1000M ~ 2000M).

Please do not operate any high-frequency, remote control or radio equipment near the components of electric drive and control system and their power cables. If the use of the equipment cannot be avoided, check the machine or installation during initial commissioning. Observe possible malfunctions when operating such equipment with high frequency, remote control and radio in their normal position. Special electromagnetic compatibility (EMC) test may be required.

#### **DANGER**

##### **Danger from hot surface!**



- ◆ Do not place flammable materials around the AC servo motor, servo drive or regenerative resistor.
- ◆ Do not use the product in an environment with corrosive, flammable gases or flammable materials.
- ◆ Do not touch the surface of the AC servo motor, servo drive or regenerative resistor which will be hot while operating.

#### **WARNING**



##### **Personal injury or damage to property.**

- ◆ The environment temperature will rise due to motor operation.
- ◆ AC servo motor grounding terminal must be installed properly.

### 3.3.6 De-rating curve

The rated value of AC servo motor is the continuous allowable value at the ambient air of 40°C when a heat sink is installed. The dimensions of the heat sinks used for different types of AC servo motors are shown in Table 3.3.6.1. If the AC servo motor is operated over 40°C ( Maximum 60°C), please apply the appropriate derating curve as shown in Figure 3.3.6.1 ~ Figure 3.3.6.8, if a heat sink of sufficient size can't be used, reduce the load according to Figure 3.3.6.9.

Table 3.3.6.1

AC servo motor	Heat Sink Size (Material)
EM1-C-M-05 EM1-C-M-10	200(L)*200(W)*6(T)mm Aluminum Alloys
EM1-C-M-20 EM1-C-M-40 EM1-C-M-75	250(L)*250(W)*6(T)mm Aluminum Alloys
EM1-A-M-1K EM1-D-M-1A EM1-D-M-2K	300(L)*300(W)*6(T)mm Aluminum Alloys

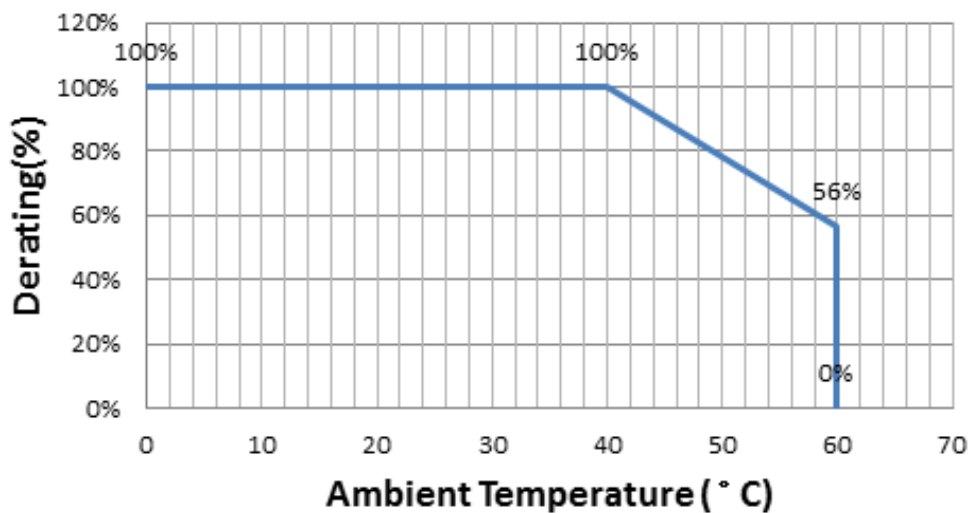

Figure 3.3.6.1 EM1-C-M-05 (50 W)

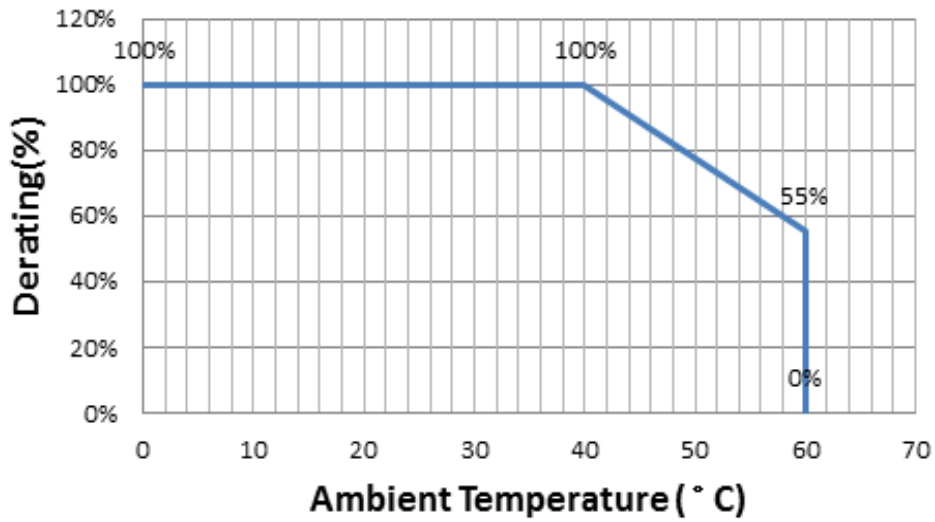

Figure 3.3.6.2 EM1-C-M-10 (100 W)

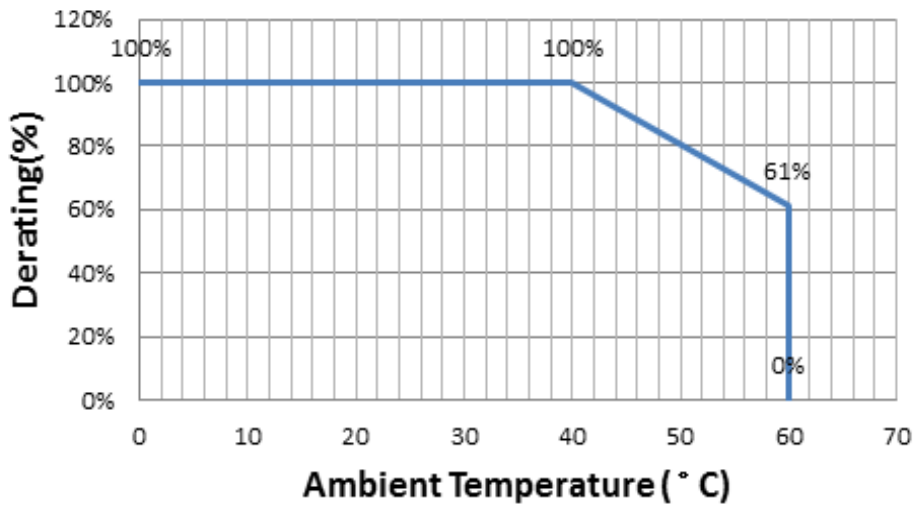

Figure 3.3.6.3 EM1-C-M-20 (200 W)

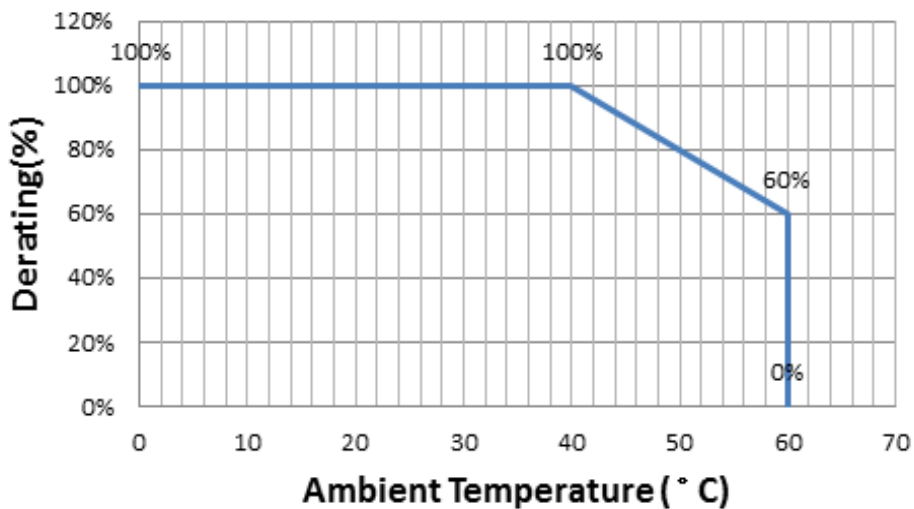

Figure 3.3.6.4 EM1-C-M-40 (400 W)

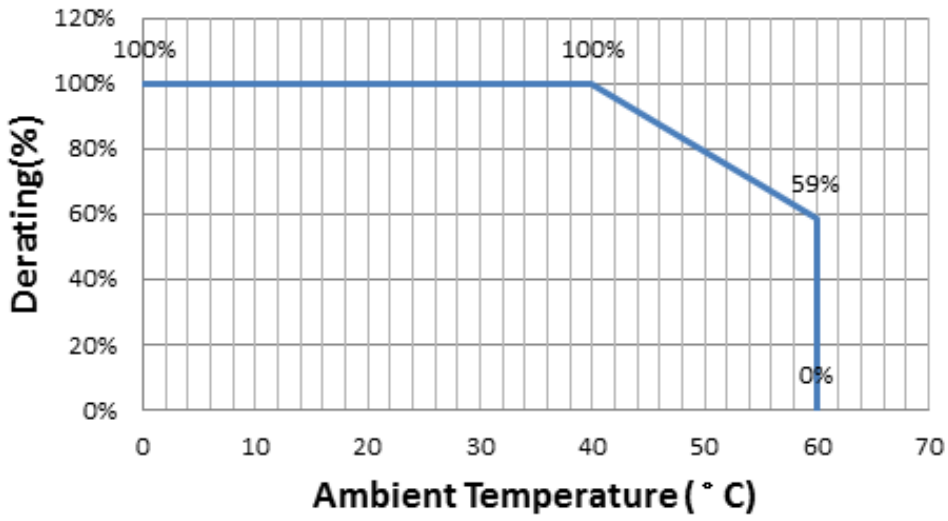

Figure 3.3.6.5 EM1-C-M-75 (750 W)

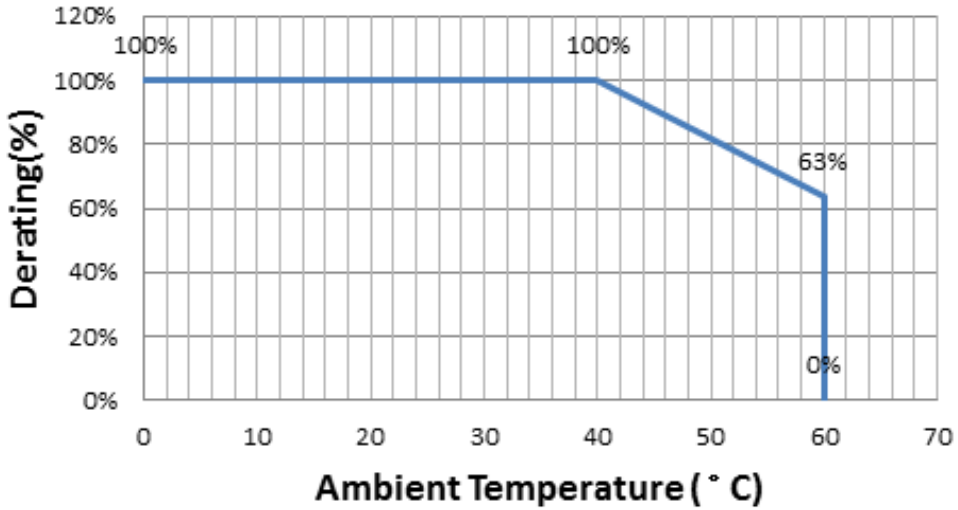

Figure 3.3.6.6 EM1-A-M-1K (1 kW)

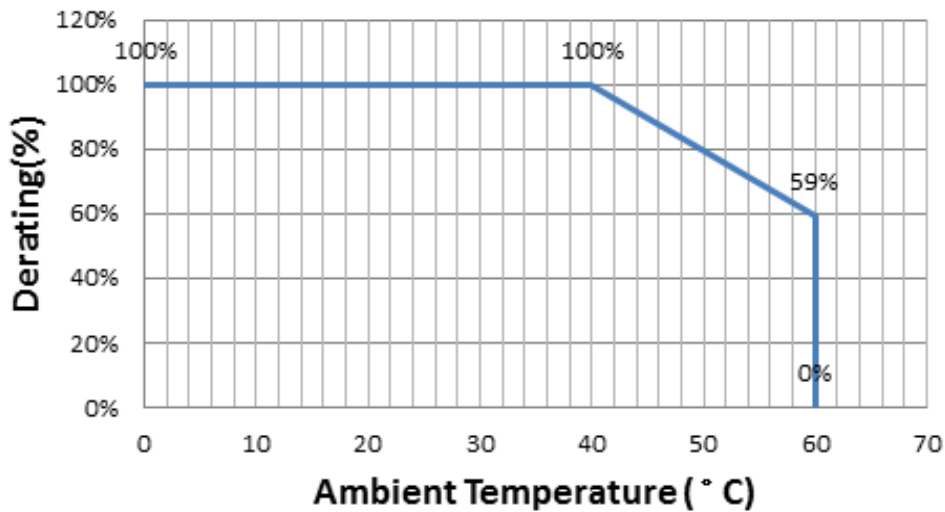

Figure 3.3.6.7 EM1-D-M-1A (1.2 kW)



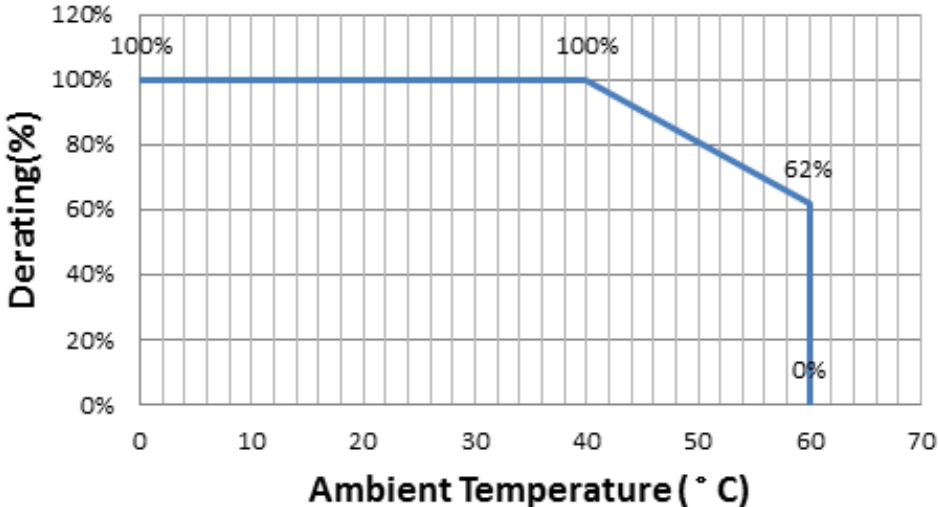

Figure 3.3.6.8 EM1-D-M-2K (2 kW)

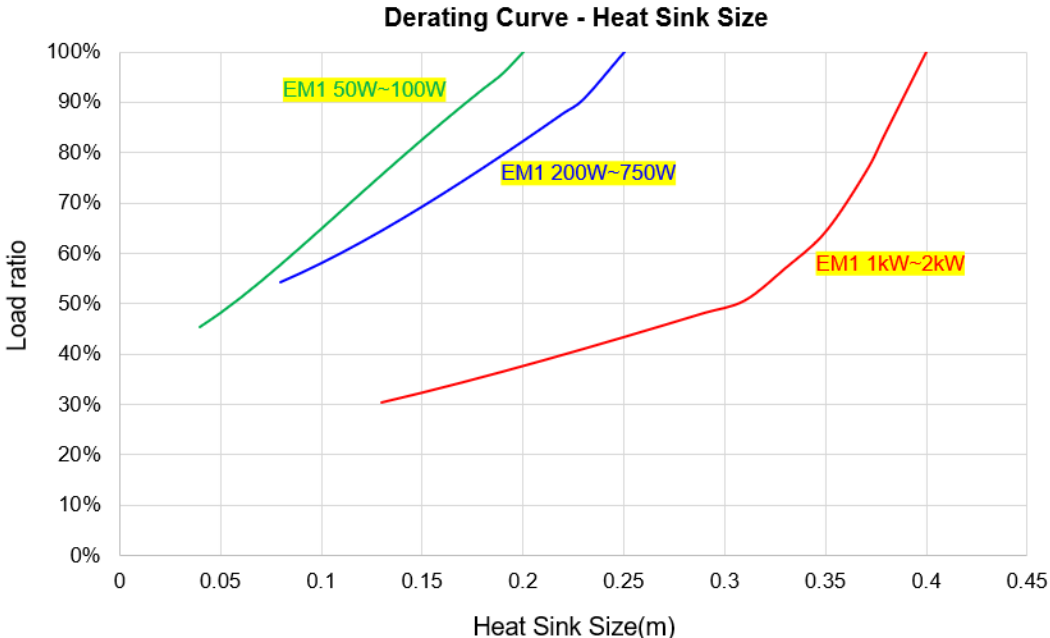

Figure 3.3.6.9 Heat sink size VS Load ratio

(This page is intentionally left blank.)

## 4. Transport and setup

---

4.	Transport and setup .....	4-1
4.1	Delivery .....	4-2
4.1.1	Delivery state .....	4-2
4.1.2	Scope of delivery.....	4-2
4.1.3	Delivery ambient conditions .....	4-2
4.2	Transport to the installation site.....	4-3
4.3	Requirements at the installation site.....	4-4
4.4	Storage .....	4-5
4.5	Unpacking and setup .....	4-6

## 4.1 Delivery

### 4.1.1 Delivery state

The AC servo motors are supplied with complete assembly, function examination, and connecting preparation. To prevent damage during transportation, the AC servo motors are provided with transportation safety devices and shipping devices.

### 4.1.2 Scope of delivery

For the scope of delivery, please refer to the contractual documentation.

### 4.1.3 Delivery ambient conditions

Table 4.1.3.1

Environmental parameter	Description
Air temperature	-15°C ~ 55°C
Relative humidity	20% ~ 80%
Rate of change of temperature	0.5°C /min
Air pressure	70 kPa ~ 106 kPa
Condensation	Not allowed
Formation of ice	Not allowed
Delivery the motor in an environment with good protection. (indoor/factory)	

Note:

- (1) Avoid exposing to direct sunlight.
- (2) Keep away from electric magnetic interference source sites such as welding and discharge machines.

## 4.2 Transport to the installation site

### **DANGER**

#### **Danger from strong magnetic fields!**



- ◆ Strong magnetic fields around AC servo motor pose a health risk to persons with implants (e.g., cardiac pacemakers) that are affected by magnetic fields.
- ◆ People with implants are affected by magnetic fields should maintain a safe distance of at least 1 m from the AC servo motor.

### **WARNING**

#### **Risk of personal injury.**



- ◆ Lifting heavy loads may damage your health.
- ◆ For total load of package with AC servo motor weight over 20 kg, use a hoist of an appropriate size when positioning heavy loads!
- ◆ Check applicable occupational health and safety regulations when handling suspended loads!

### **CAUTION**

#### **Risk of physical damage to watches and magnetic storage media.**



- ◆ Strong magnetic force may destroy watches and magnetizable data storage media near the AC servo motor!
- ◆ Do not bring watches or magnetizable data storage media in the vicinity (<300 mm) of the AC servo motor!

### **CAUTION**

#### **Risk of damage to the AC servo motor!**



#### **The AC servo motor may be damaged by mechanical loading.**

- ◆ No heavy load on the cover!
- ◆ During transportation, do not put any additional loads on the AC servo motors.

## 4.3 Requirements at the installation site

Table 4.3.1

Air temperature	0°C ~ 50°C
Relative humidity	< 80% RH (non-condensing)
Altitude	< 1000m
Installation site	Flat, dry, vibration-free
Protection class	No interference from corrosive solvent or strong magnetic
Grounding	Plant power grounding line conforms to international requirements

Note:

- (1) Avoid exposing to direct sunlight.
- (2) Keep away from electric magnetic interference source sites such as welding and discharge machines.

## 4.4 Storage

 **DANGER**

**Danger from strong magnetic fields!**



- ◆ Strong magnetic fields around AC servo motor pose a health risk to persons with implants (e.g., cardiac pacemakers) that are affected by magnetic fields.
- ◆ People with implants are affected by magnetic fields should maintain a safe distance of at least 1 m from the AC servo motor.

- Store the AC servo motor in its transportation packaging.
- Only store the AC servo motor in dry, frost-free areas with a corrosion-free atmosphere.
- Clean and protect used AC servo motor before storage.
- When storing AC servo motor, attach signs warning of magnetic fields.

Table 4.4.1

Environmental parameter	Description
Air temperature	-15°C ~ 70°C
Relative humidity	20% ~ 80%
Rate of change of temperature	0.5°C /min
Air pressure	70kPa ~ 106kPa
Condensation	Not allowed
Formation of ice	Not allowed
Store the motor in an environment with good protection. (indoor/factory)	

## 4.5 Unpacking and setup

### CAUTION



**Risk of damage to the AC servo motor!**

**The AC servo motor may be damaged by mechanical loading.**

- ◆ No heavy load on the cover!
- ◆ During transportation, do not put any additional loads on the AC servo motors.

Note:

- (1) The AC servo motor can only be unpacked indoors.
- (2) The AC servo motor (50 W ~ 750 W) are provided with power outgoing line and encoder outgoing line. During unpacking, the outgoing line of AC servo motor must not be bended or pulled.

■ Procedure of unpacking the AC servo motor:

Step 1: Unbox the carton and take out the AC servo motor.

Step 2: Remove protective film and shaft cover outside the AC servo motor.

Step 3: Do not touch the shaft by hand without gloves to prevent shaft from getting rusted.

Step 4: Carefully handle the outgoing line from the AC servo motor. Do not bend or pull the wiring.

Step 5: Ensure the appearance and nameplate on AC servo motor are the same with the catalogue.

Step 6: Dispose of packaging in an environmentally friendly way.



## 5. Assembly and connection

5.	Assembly and connection .....	5-1
5.1	Mechanical installation.....	5-2
5.1.1	Installation environment .....	5-2
5.1.2	Tools and equipment.....	5-3
5.1.3	Servo motor installation .....	5-4
5.1.3.1	Motor .....	5-4
5.1.3.2	Oil seal.....	5-7
5.1.3.3	Key .....	5-8
5.1.3.4	Belt .....	5-11
5.1.3.5	Coupling .....	5-12
5.1.3.6	Safety brakes .....	5-15
5.2	Electrical installation .....	5-17
5.2.1	Motor cable pin assignment.....	5-17
5.2.1.1	Motor power cable connector .....	5-17
5.2.1.2	17 bit / 23 bit Incremental encoder cable connector .....	5-21
5.2.1.3	17 bit / 23 bit Absolute encoder cable connector .....	5-23
5.2.1.4	Allowable bending radius .....	5-27
5.2.2	Electrical connection .....	5-28

## 5.1 Mechanical installation

### 5.1.1 Installation environment

- Operating temperature: 0°C ~ 50°C (Derating is required at 40°C ~ 50°C to avoid condensation and icing).
- Operating humidity: 20% ~ 80% RH (Avoid condensation and icing).
- Storage temperature: -15°C ~ 70°C (Avoid condensation and icing).
- Storage humidity: 20% ~ 80% RH (Avoid condensation and icing).
- Vibration/Shock resistance: Less than 49m/s<sup>2</sup> (In three direction: vertical, side to side, and front to back)
- Elevation: Less than 1000M (Derating is required at 1000M ~ 2000M to avoid condensation and icing).
- Installation Precautions:
  - (1) Please install the product indoors, away from direct sunlight.
  - (2) Please install the product in a site without humidity, dust or hazardous/corrosive gases or liquids.
  - (3) The AC servo motor's shaft is not waterproof or oil-proof. Thus, do not install or use the AC servo motor in an environment with water or oil droplets, excessively high humidity or corrosive/flammable gases.
  - (4) Do not store the product in a site with vibration that exceeds the quantity stated in the specification document.
  - (5) The AC servo motor shaft material is not rust-resistant. Grease has been applied to prevent rust before the products were shipped. However, if the storage time exceeds six months, inspect the shaft every three months to make sure that it is not rusted. Apply an appropriate amount of rust-prevention grease when needed.

## 5.1.2 Tools and equipment

### ■ Installation

Table 5.1.2.1

Item	Tool
Motor	Torque wrench
Oil seal	-
Key	Hand press machine
Belt	Screwdriver or wrench
Cable	-

### ■ Personal protective equipment

In the vicinity of AC servo motor systems, the following personal protective equipment is required:

- (1) Safety shoes.
- (2) Protective helmet.
- (3) Protective gloves.

### 5.1.3 Servo motor installation

#### 5.1.3.1 Motor

■ Orientation

Horizontal: cable lead must face downward to prevent oil or water penetration.

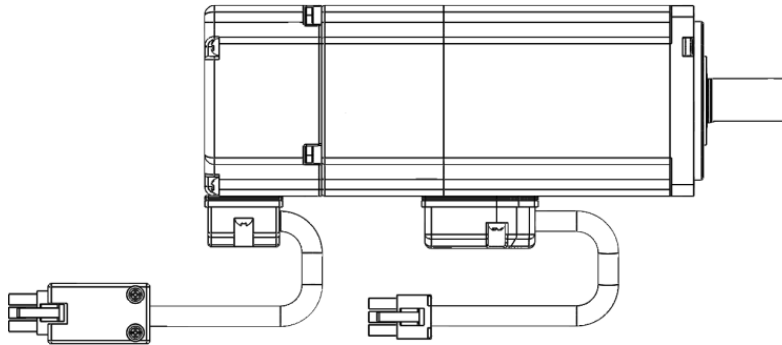

Figure 5.1.3.1.1

Vertical: when the motor shaft mounted with reducer is installed upwards, oil seal must be used to prevent the reducer oil from flowing into the motor.

■ Installation interface

The motor rated specifications (rated output, rated torque, and rated speed) are used in an ambient temperature below 40°C (Derating is required at 40°C ~ 50°C to avoid condensation and icing) when servo motors are installed with the following heat sinks and screws.

Table 5.1.3.1.1

Motor	PCD screw hold (mm)	Interface (mm)	Screw type	Tightening torque
50 W ~ 100 W	4.3	200x200x6 Aluminum plate	2*M4x20L	1.63 N-m(16.6 kgf-cm) ±10%
200 W ~ 400 W	5.5	250x250x6 Aluminum plate	2*M5x20L	3.28 N-m(33.4 kgf-cm) ±10%
750 W	6.6	250x250x6 Aluminum plate	2*M6x20L	5.58 N-m(56.9 kgf-cm) ±10%
1 kW ~ 2 kW	9	400x400x20 Iron plate	2*M8x20L	13.5 N-m(138 kgf-cm) ±10%

Note: 1 N-m ≙ 10.1972 kgf-cm

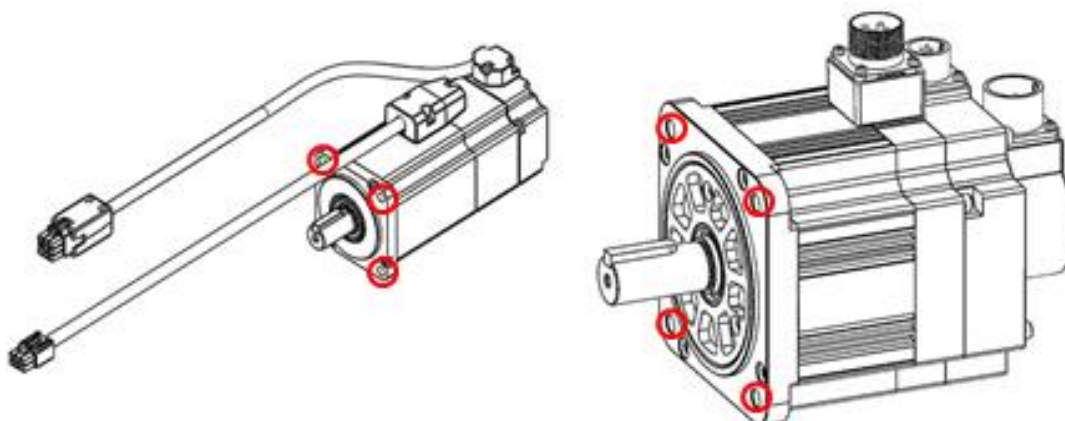

Figure 5.1.3.1.2

EM1-C-M-05 / EM1-C-M-10 is equipped with 2\*M4\*12L special hex socket screws for customer flange installation.

#### ■ Protective structure

HIWIN servo motor protective structure is described below.

(1) 50 W ~ 750 W: IP65

Except for power connector, encoder connector, shaft section of the motor also needs to add oil seal, which is optional for all types of AC servo motor.

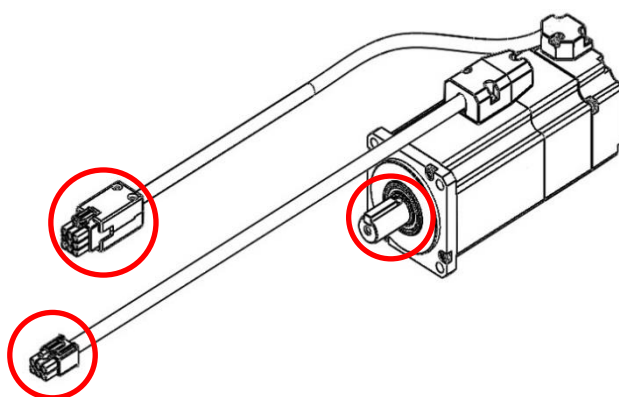

Figure 5.1.3.1.3

## (2) 1 kW ~ 2 kW: IP65

For 1 kW ~ 2 kW AC servo motors, the protective structure specifications will only be fulfilled when the cable is connected to military connector. Shaft section of the motor needs to add oil seal, which is optional for all types of AC servo motor.

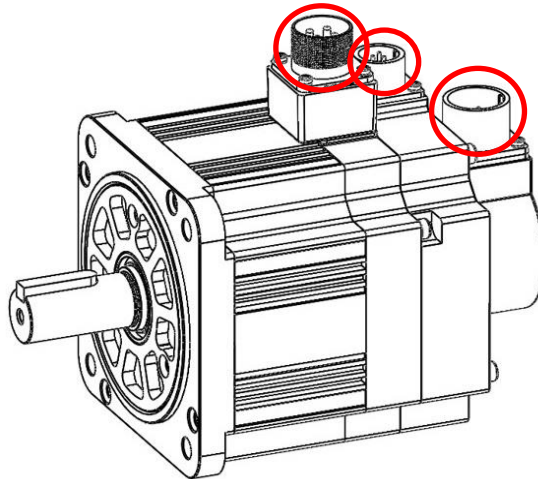

Figure 5.1.3.1.4

## ■ Preparation

Please follow the instructions below to prepare motor assembly:

- (1) Purchase tools, supplies, measuring and testing equipment.
- (2) Check all components for visible damage. Damaged components should not be mounted.
- (3) Ensure that dimensions and tolerances on the system are suitable for motor installation (for details, please refer to the dimension sheet).
- (4) Inspect all components, mounting surfaces and threads to ensure they are clean.
- (5) Make sure that the assembly can be carried out in a dry and dust-free environment.
- (6) Make sure that the holder of the motor flange is deburred.
- (7) Remove the protective sleeve of the motor shaft and keep it for further use.

## ■ Assembly

Assemble the motor and observe that:

- (1) Avoid inserting any parts that may damage the system.
- (2) Install the motor to the machine and check the tightening torques.
- (3) Check if the connection is firm and accurate before carrying out any further steps.

After the motor is installed to the machine, prepare for electrical connection. (See section 5.2 Electrical installation)

### 5.1.3.2 Oil seal

- If the shaft opening of the AC servo motor is easily affected by oil spray in the operation environment, please use motor with an oil seal.
- Check the operation environment to make sure that the oil seal material is appropriate.
- The usage of oil seal should not be lower than the oil surface. The oil may leak in through the opening of motor flange to damage the AC servo motor.

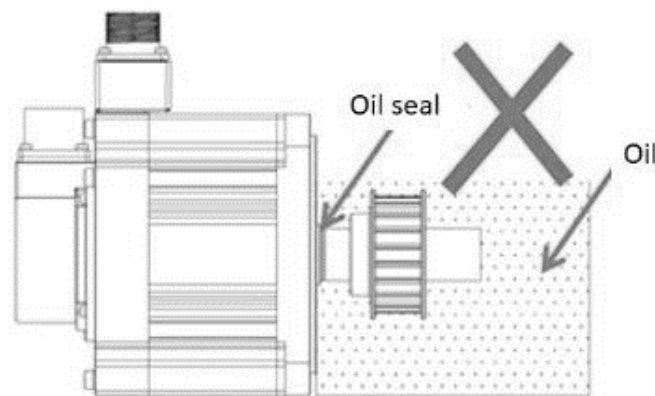

Figure 5.1.3.2.1

### 5.1.3.3 Key

■ Installation procedures:

- (1) Clean the dirt on the keyway.
- (2) Clean the dirt on the key.
- (3) Put the key onto the shaft keyway without deviation.
- (4) Press the key into the keyway.

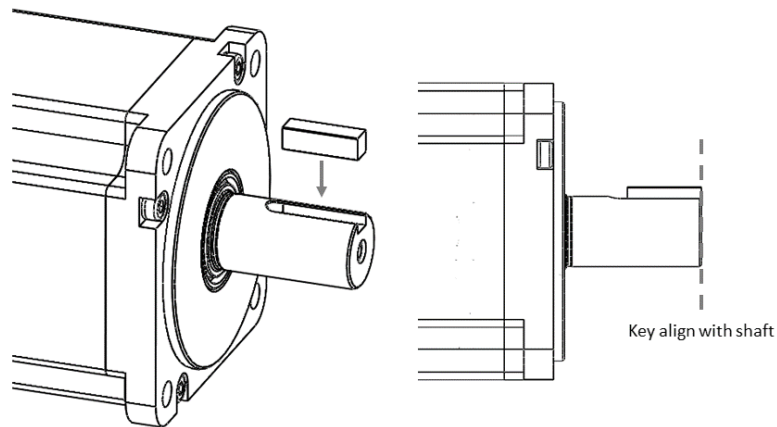

Figure 5.1.3.3.1

- (5) Lean the shaft on a solid surface and make sure to press the key vertically. The velocity of pressing should be under 400mm/min. Punching is prohibited.

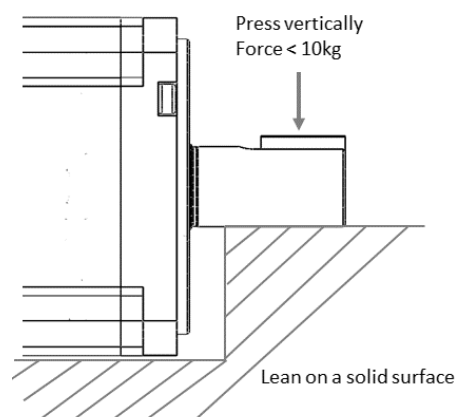

Figure 5.1.3.3.2



(6) Press key vertically to the bottom side. Press height is as table 5.1.3.3.1.

Table 5.1.3.3.1 Press height

Motor Type	Press Height (mm)
50 W / 100 W	1.8
200 W / 400 W	3
750 W	3.5
1 kW / 2 kW	4

(7) Make sure the key is pressed to the bottom of the keyway.

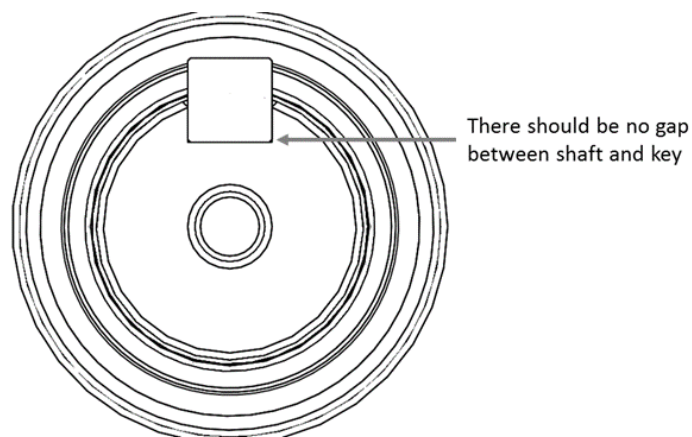

Figure 5.1.3.3.3

■ Uninstallation procedures:

➤ 50 W / 100 W

Step 1: Remove plastic cover from the shaft.

Step 2: Prepare diagonal pliers.

Step 3: Clip the key with the pliers.

Step 4: Remove the key from the shaft.

➤ 200 W / 400 W / 750 W / 1 kW / 2 kW

Step 1: Remove plastic cover from the shaft.

Step 2: Attach a jig on the motor shaft.

Step 3: Rotate the jig clockwise.

Step 4 Couple the puller with the jaws.

Step 5: Rotate the puller clockwise to remove the key from the keyway.

## WARNING

### Risk of personal injury or damage to property.

- ◆ When putting the key that comes with the product or a key designated by the manual into the keyway, do not directly strike the shaft, which may cause damage.

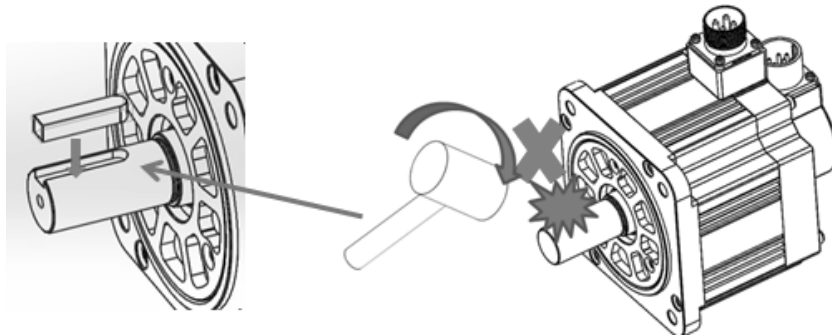

## CAUTION

### Risk of personal injury or damage to property.

- ◆ Be sure that the key is pressed vertically.
- ◆ Be careful with the sharp keyway when cleaning or installing the key.



**5.1.3.4 Belt**

- Choose a belt that is suitable for the allowable radial load and output power of the AC servo motor.
- When the motor accelerates or decelerates, the reaction force of the acceleration/deceleration will increase the initial belt tension. Thus, when choosing a belt, please consider the load of motion and the belt’s safety coefficient.
- When installing the belt, suitably adjust the belt tension force and consider the allowable radial load stated in the manual. Please refer to the following information.

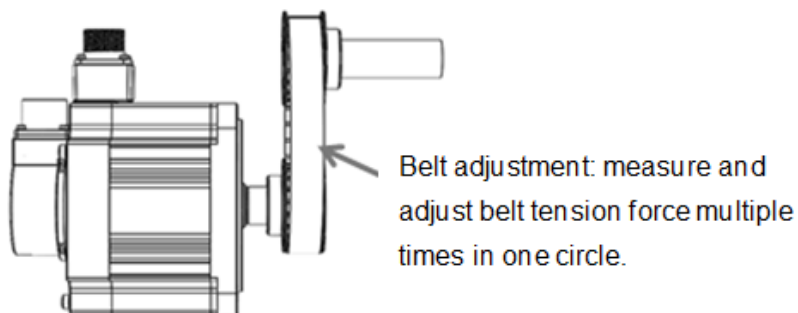

Figure 5.1.3.4.1

- Motor shaft allowable axial and radial force.

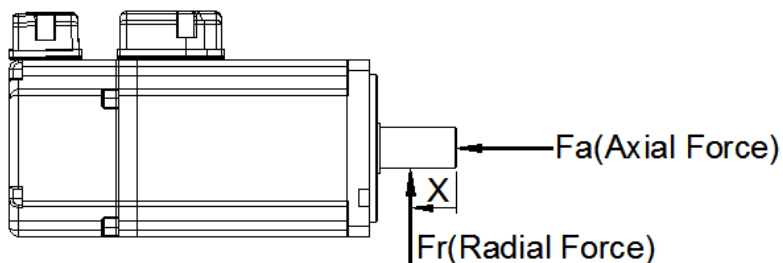

Figure 5.1.3.4.2

$F_a$  (Allowable axial force):

Table 5.1.3.4.1

Flange size	Allowable axial force
40mm	54N
60mm	74N
80mm	147N
130mm	343N

$F_r$  (Allowable radial force):

Table 5.1.3.4.2

Flange size	Allowable radial force (X) [Force unit: Newton], [X unit: mm]										
	x=0	x=5	x=10	x=15	x=20	x=25	x=30	x=35	x=40	x=45	x=50
40mm	68	74	80	88	98	-	-	-	-	-	-
60mm	190	200	215	230	245	270	-	-	-	-	-
80mm	340	350	365	380	395	415	435	-	-	-	-
130mm	640	660	685	715	745	775	810	850	890	940	990

**5.1.3.5 Coupling**

- Before installation, please clean and remove the rust spots, dust and oil on the motor shaft and the inner surface of the coupling, especially molybdenum, silicon and fluorine type lubricant or esters, which may affect the friction coefficient and should never be on the motor shaft and coupling.
- Choose a suitable coupling based on the load conditions. Excessively large or small coupling may cause damage.
- When the two clamping bolts on the coupling are loose, check if the coupling can slightly move in the axial direction and rotational direction. If it cannot move smoothly, re-adjust the concentricity of both motor shaft and coupling. This is an easy way to check the concentricity between the two. If this method cannot be adopted, please use machine part precision management or other methods to ensure installation accuracy.

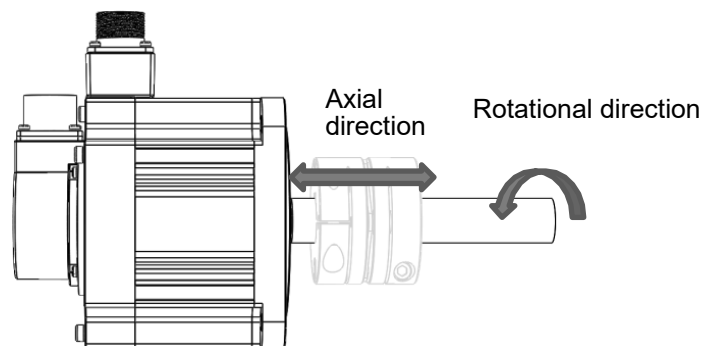

Figure 5.1.3.5.1

- When installing the coupling on the motor shaft, do not apply too much compressive force or tensile strength, and do not subject the motor shaft to shock, or it may affect the installation precision.

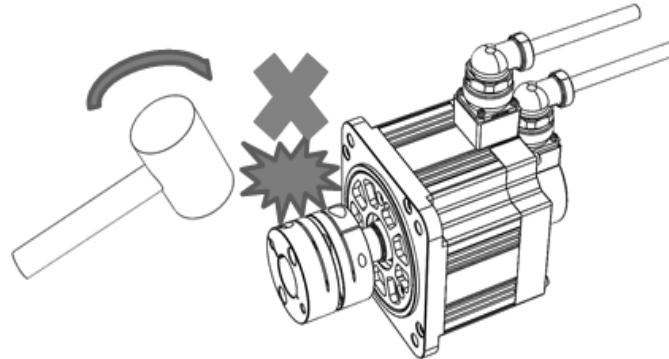

Figure 5.1.3.5.2

- Before inserting the coupling to the motor shaft, do not fasten the screw bolt.
- When choosing the coupling, do not exceed the maximum torque limit of the transmission. Choose the model based on the allowable eccentricity, declination, and axial direction deviation stated in the manual.
- If an abnormal coupling noise (metallic noise) is discovered during operations, stop operation immediately and check if there is shaft the eccentricity or if the screws are loose.
- Do not replace the screws that match the coupling. Please refer to the specifications to change the screws.
- Do not touch coupling while operating. To prevent danger, install a protective outer cover and adopt other safety measures.
- Conduct installation only when the main power is OFF.
- When installing the motor, be aware of the following three types of basic deviation, as shown below:

1. Eccentricity(A):

2. Declination(B):

3. Axial direction displacement (C):

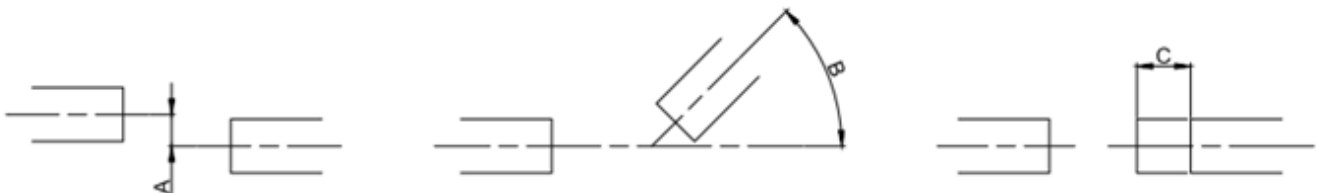

Figure 5.1.3.5.3

- The simple method for calibration of the centerline between two axis is to loosen the coupling located on the shaft of AC servo motor and the load end's shaft shoulder, and rotate the coupling to confirm if it can slightly move in axial and rotational direction, to confirm the concentricity of the two axes. Refer to the diagram as follows:

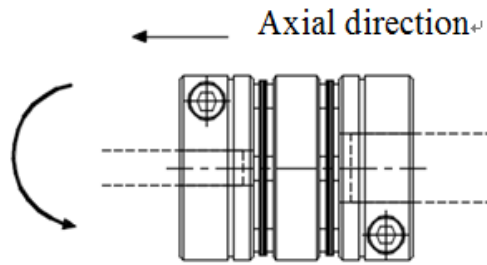

Figure 5.1.3.5.4

- Please check the concentricity when installing through motor flange and the PCD hole position of the flange. The size of the recommended flange holes for installation is shown as below.

Table 5.1.3.5.1

Motor output power	Flange circle size	Tolerance
50 W ~ 100 W	30mm	H7
200 W ~ 400 W	50mm	H7
750 W	70mm	H7
1 kW ~ 2 kW	110mm	H7

- When installing the motor flange, please make sure that the deviation between the motor flange position hole and the load-end's shaft shoulder need to be within the coupling's related allowable deviation.
- If the deviation between the motor shaft and the load-end's shaft shoulder is too large, and the coupling is forcefully installed, it may break the motor shaft, coupling, or load end's shoulder. Therefore, make sure that the deviation between the two axes are within the coupling's allowable deviation.
- When choosing a coupling, it is recommended to choose a flexible coupling that can absorb the eccentricity, declination and axial direction displacement.

### 5.1.3.6 Safety brakes

#### ■ Precautions for using safety brakes

- (1) The brake is used to keep the motor at a stop for long-period holding or for emergency stop in case of power shortage. Do not use the brake for dynamic braking to perform motor emergency stop, or it may be damaged from improper use.
- (2) Before operating the motor, check the supply power and function of the brake. For other detailed information, please refer to the sequence diagram in the manual.
- (3) The brake voltage is DC 24V. Check the input voltage before use.
- (4) Before operating the servo motor, check the braking and release time of the brake's armature.
- (5) Environment for brake operation: if there is water or oil on the friction surface of the brake, the braking torque would be decreased. Since the cable is not oil-resistant, an outer cover must be used for protection in an environment with oil or grease,.

#### ■ The following conditions are often mistaken for brake damage

- (1) Heat: even if the servo motor is shut off, the power that maintains the brake holding will heat up the servo motor.

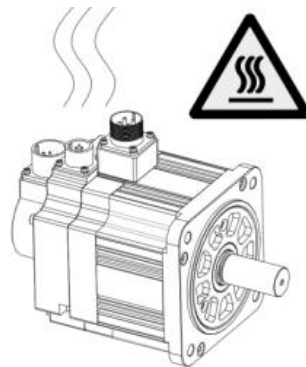

- (2) Rotational backlash: The brake still have the rotational backlash in holding state. The maximum rotational backlash is within 2 degrees.

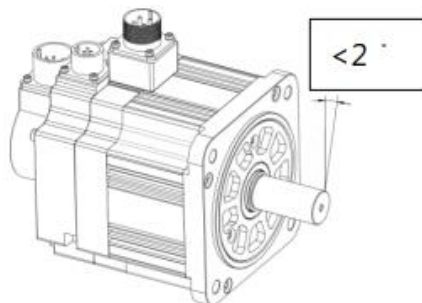

- (3) Noise: when the motor is operating at a low rotation, accelerating, stopping or changing directions, sometimes the friction plate will produce a noise. This is not a malfunction noise but a sound from the brake module structure, which will not affect motor function.

**■ Brake maintenance and inspection**

Maintaining and inspecting the brakes regularly may prolong its function.

- (1) Check if the ON/OFF operation is correct.
- (2) Check if there are any noises.
- (3) Check if there is abnormal heating.
- (4) Check if the release time is abnormal.
- (5) Check if the input voltage is correct.



## 5.2 Electrical installation

### 5.2.1 Motor cable pin assignment

#### 5.2.1.1 Motor power cable connector

- Small capacity series / 50 W ~ 750 W

Table 5.2.1.1.1 HVPS04AB / HVPS06AB (with ED1 drive)

Signal	AMP 172159-1 AMP 170360-1		AMP 172160-1 AMP 170360-1		-	Conductors	Insulators
	(without brake)		(with brake)				
U	3	Red	3	Red	European terminal	18AWG	2.8mm
V	2	White	2	White	European terminal	18AWG	2.8mm
W	1	Black	1	Black	European terminal	18AWG	2.8mm
GND	4	Green	4	Green	R type terminal	18AWG	2.8mm
B+	--	--	5	Yellow	European terminal	18AWG	2.8mm
B-	--	--	6	Blue	European terminal	18AWG	2.8mm

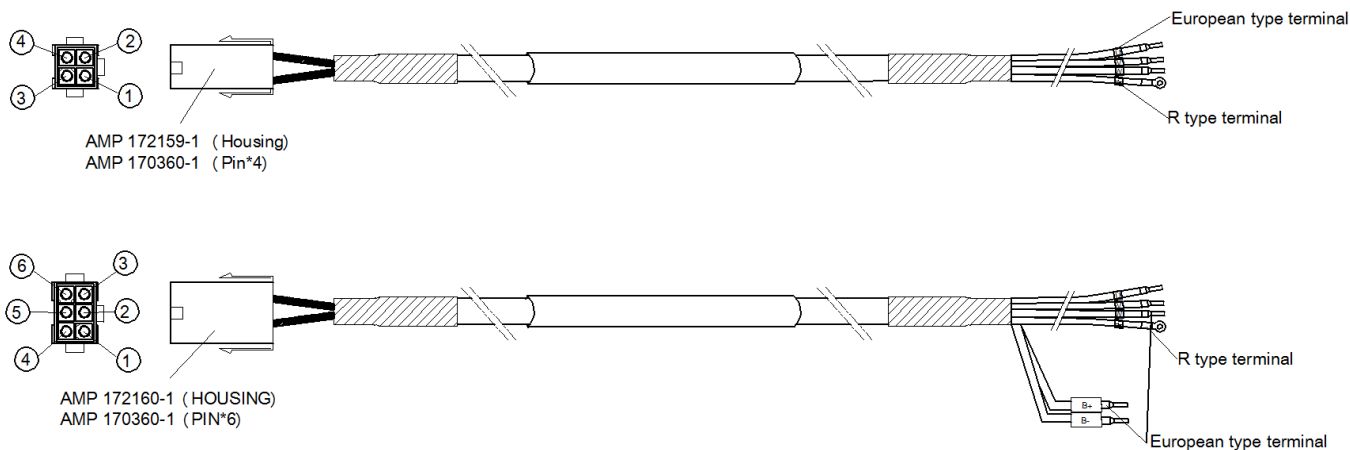

Figure 5.2.1.1.1

Table 5.2.1.1.2 HVPS04AA / HVPS06AA (with ED2 drive)

Signal	AMP 172159-1 AMP 170360-1		AMP 172160-1 AMP 170360-1		-	Conductors	Insulators
	(without brake)		(with brake)				
U	3	Red	3	Red	European terminal	18AWG	2.8mm
V	2	White	2	White	European terminal	18AWG	2.8mm
W	1	Black	1	Black	European terminal	18AWG	2.8mm
GND	4	Green	4	Green	European terminal	18AWG	2.8mm
B+	--	--	5	Yellow	European terminal	18AWG	2.8mm
B-	--	--	6	Blue	European terminal	18AWG	2.8mm

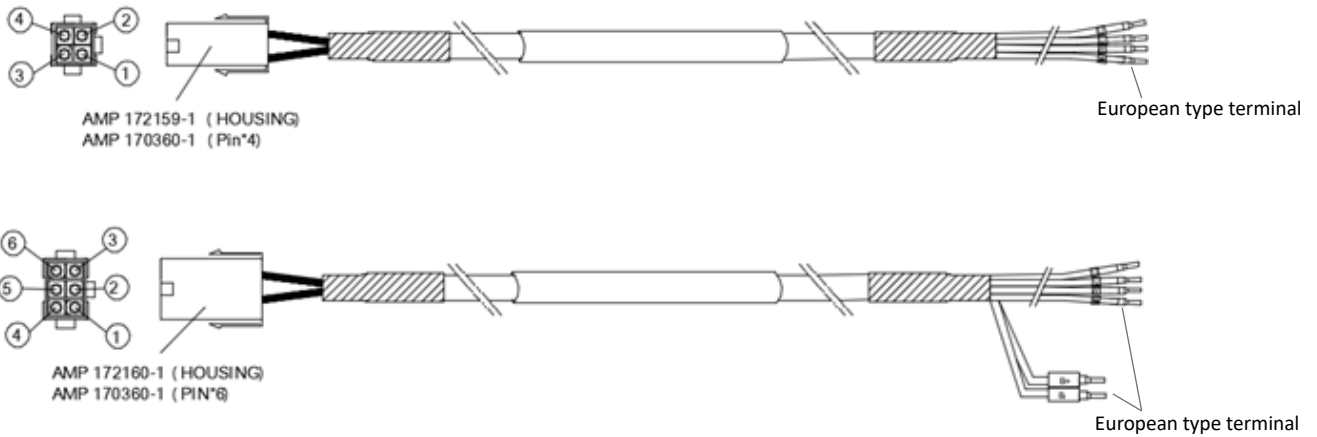

Figure 5.2.1.1.2

■ Middle capacity series / 1 kW ~ 2 kW

Table 5.2.1.1.3 HVPM04BB / HVPM04CB / HVPM02BA / HVPM02CA (with ED1 drive)

Signal	WPS3106A18-10S-R WPS3108A18-10S-R		WPS3106A14S-7S-R WPS3108A14S-7S-R		-	Conductors	Insulators
U	A	Red	--	--	European terminal	14AWG	3.6mm
V	B	White	--	--	European terminal	14AWG	3.6mm
W	C	Black	--	--	European terminal	14AWG	3.6mm
GND	D	Green	--	--	R type terminal	14AWG	3.6mm
B+	--	--	A	White	European terminal	20AWG	1.8mm
B-	--	--	C	Black	European terminal	20AWG	1.8mm

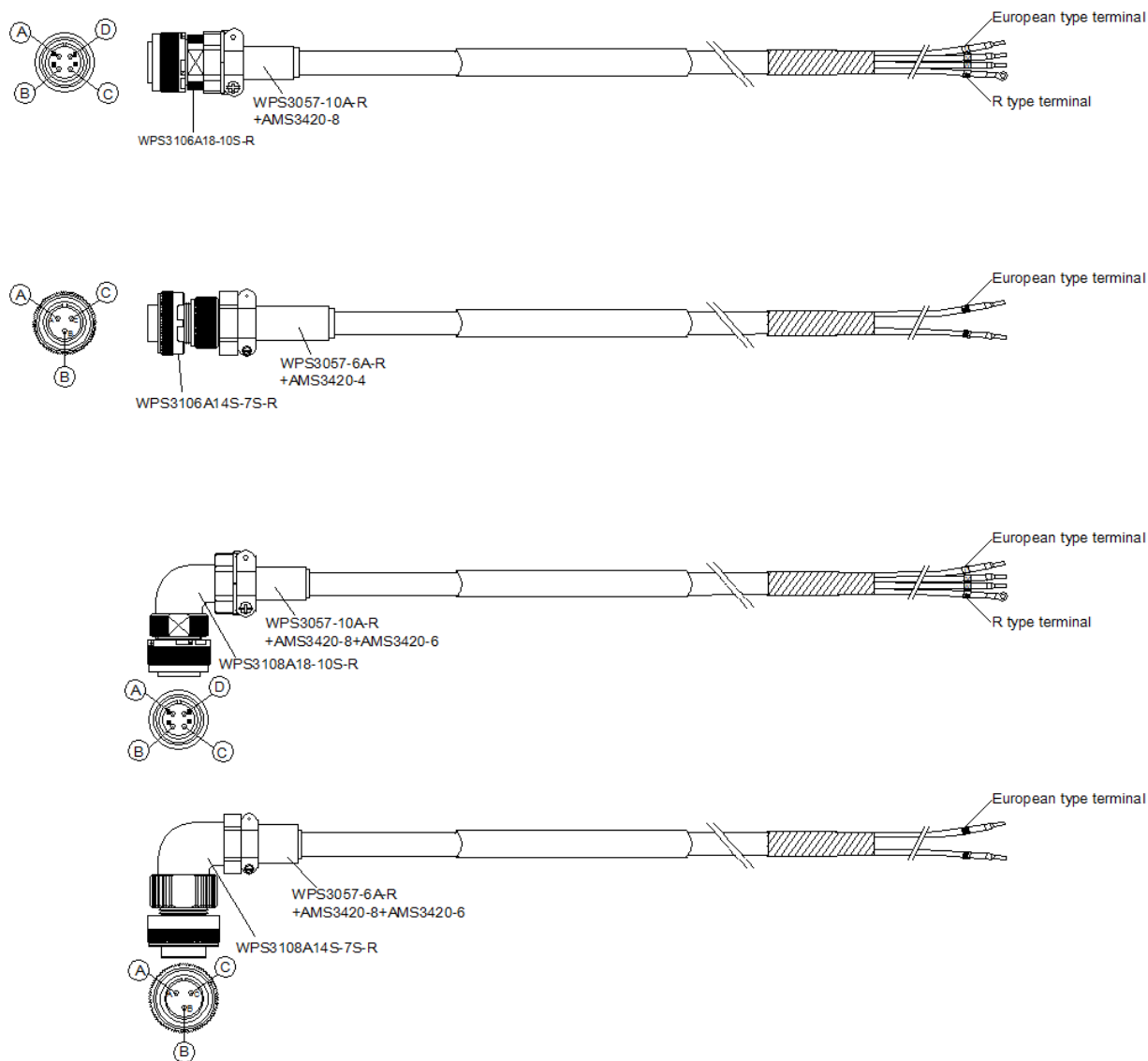

Figure 5.2.1.1.3

Table 5.2.1.1.4 HVPM04BA / HVPM04CA / HVPM02BA / HVPM02CA (with ED2 drive)

Signal	WPS3106A18-10S-R WPS3108A18-10S-R		WPS3106A14S-7S-R WPS3108A14S-7S-R		-	Conductors	Insulators
U	A	Red	--	--	European terminal	14AWG	3.6mm
V	B	White	--	--	European terminal	14AWG	3.6mm
W	C	Black	--	--	European terminal	14AWG	3.6mm
GND	D	Green	--	--	European terminal	14AWG	3.6mm
B+	--	--	A	White	European terminal	20AWG	1.8mm
B-	--	--	C	Black	European terminal	20AWG	1.8mm

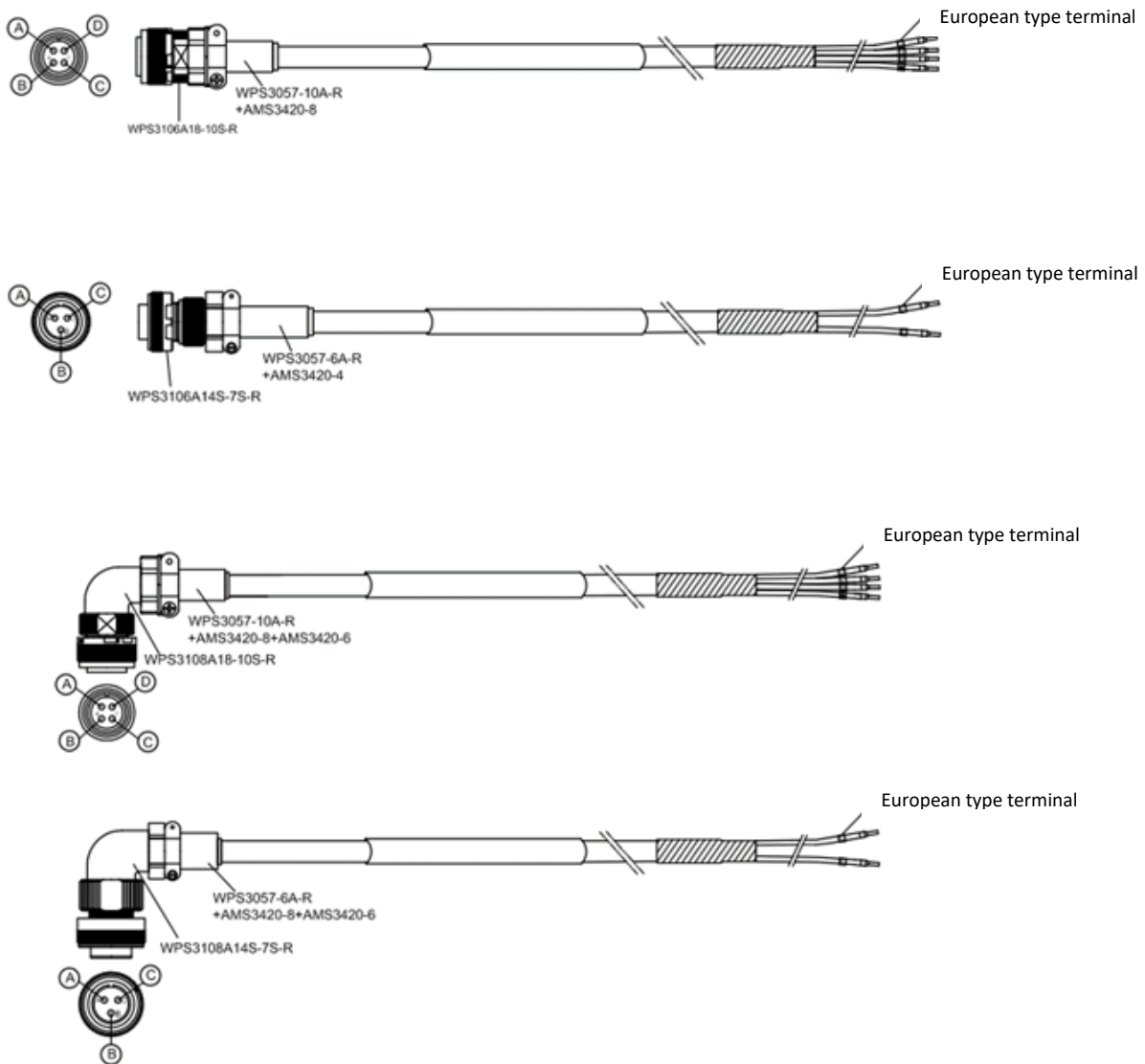

Figure 5.2.1.1.4

**5.2.1.2 17 bit / 23 bit Incremental encoder cable connector**

- Small capacity series / 50 W ~ 750 W

Table 5.2.1.2.1 HVE23IAB

Function	Signal	AMP 1-172161-9 AMP 170359-1	Color	3M 36310 3M 36210	Conductors	Insulators
Power	5V	1	Blue (Red)	1	24AWG	1.3mm
	0V	2	Blue (Black)	2	24AWG	1.3mm
Serial Data Signal	SD+	7	Yellow (Red)	3	24AWG	1.3mm
	SD-	8	Yellow (Black)	4	24AWG	1.3mm
Shielding	Shielding	9	Black	Housing	Shielding	-

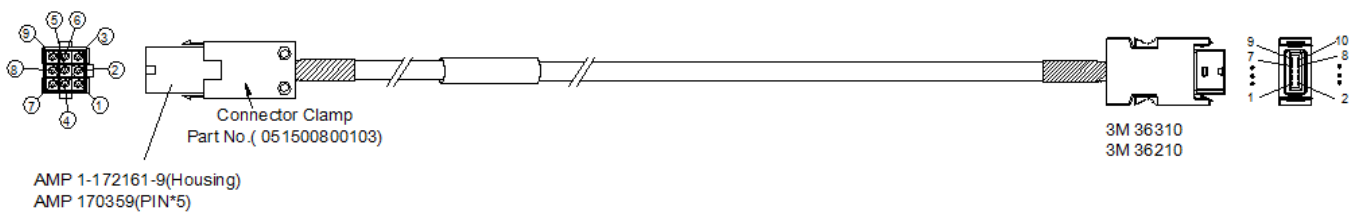

Figure 5.2.1.2.1

■ Middle capacity series / 1 kW ~ 2 kW

Table 5.2.1.2.2 HVE231BB / HVE231CB

Function	Signal	WPS 3106A18-1S-R WPS 3108A18-1S-R	Color	3M 36310 3M 36210	Conductors	Insulators
Power	5V	A	Blue (Red)	1	24AWG	1.3mm
	0V	B	Blue (Black)	2	24AWG	1.3mm
Serial Data Signal	SD+	G	Yellow (Red)	3	24AWG	1.3mm
	SD-	H	Yellow (Black)	4	24AWG	1.3mm
Shielding	Shielding	I	Black	Housing	Shielding	-

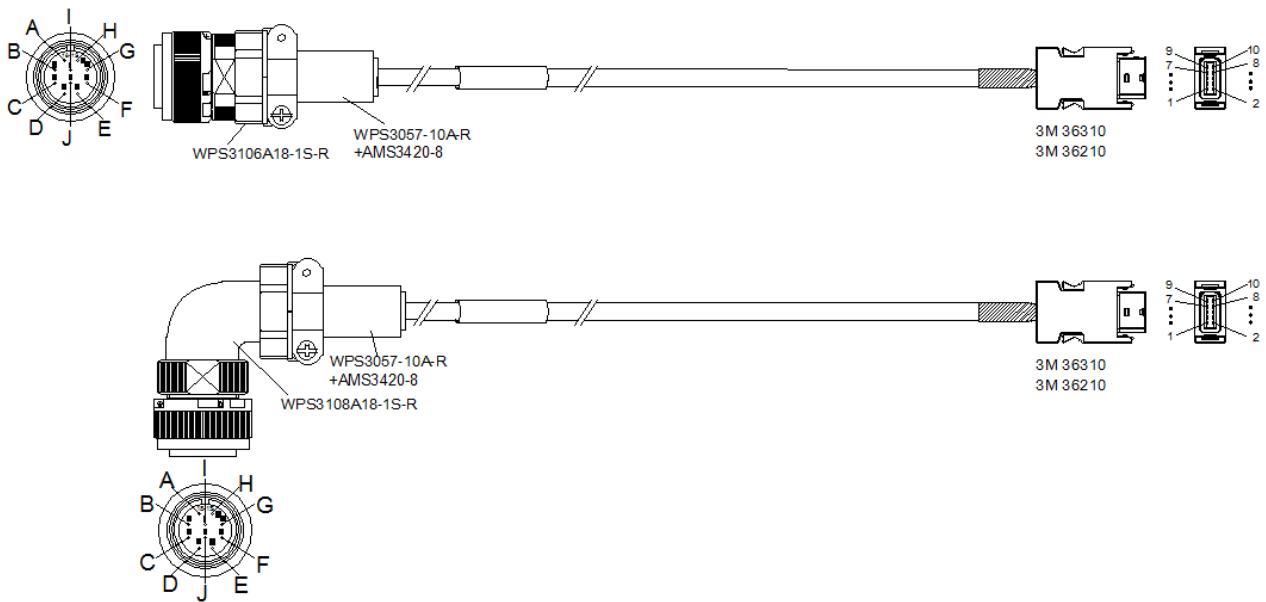

Figure 5.2.1.2.2

**5.2.1.3 17 bit / 23 bit Absolute encoder cable connector**

- Small capacity series / 50 W ~ 750 W

Table 5.2.1.3.1 HVE23AAB

Function	Signal	AMP 1-172161-9 AMP 170359-1	Color	3M 36310 3M 36210	Battery Box HRS DF3-2EP- 2C	Conductors	Insulators
Power	5V	1	Blue (Red)	1	-	24AWG	1.3mm
	0V	2	Blue (Black)	2	-	24AWG	1.3mm
Battery	VB	5	Green (Red)	-	Red	24AWG	1.3mm
	GND	6	Green (Black)	-	Black	24AWG	1.3mm
Serial Data Signal	SD+	7	Yellow (Red)	3	-	24AWG	1.3mm
	SD-	8	Yellow (Black)	4	-	24AWG	1.3mm
Shielding	Shielding	9	Black	Housing	-	Shielding	-

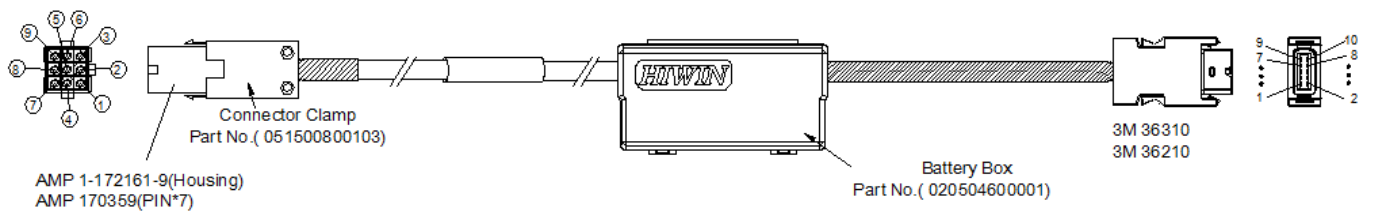

Figure 5.2.1.3.1

■ Middle capacity series / 1 kW ~ 2 kW

Table 5.2.1.3.2 HVE23ABB / HVE23ACB

Function	Signal	WPS 3106A18-1S-R WPS 3108A18-1S-R	Color	3M 36310 3M 36210	Battery Box HRS DF3- 2EP-2C	Conductors	Insulators
Power	5V	A	Blue (Red)	1	-	24AWG	1.3mm
	0V	B	Blue (Black)	2	-	24AWG	1.3mm
Battery	VB	E	Green (Red)	-	Red	24AWG	1.3mm
	GND	F	Green (Black)	-	Black	24AWG	1.3mm
Serial Data Signal	SD+	G	Yellow (Red)	3	-	24AWG	1.3mm
	SD-	H	Yellow (Black)	4	-	24AWG	1.3mm
Shielding	Shielding	I	Black	Housing	-	Shielding	-

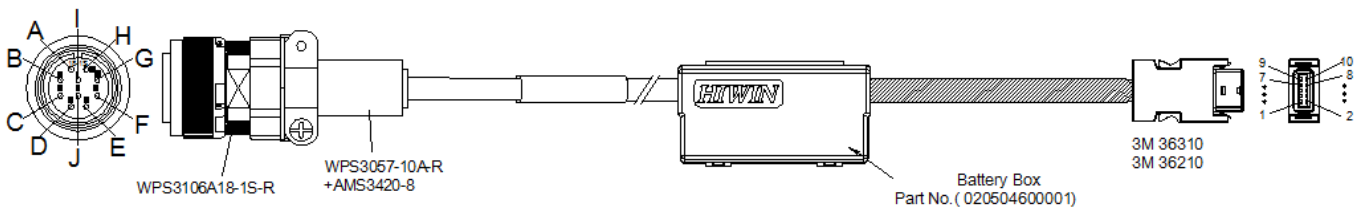

Figure 5.2.1.3.2

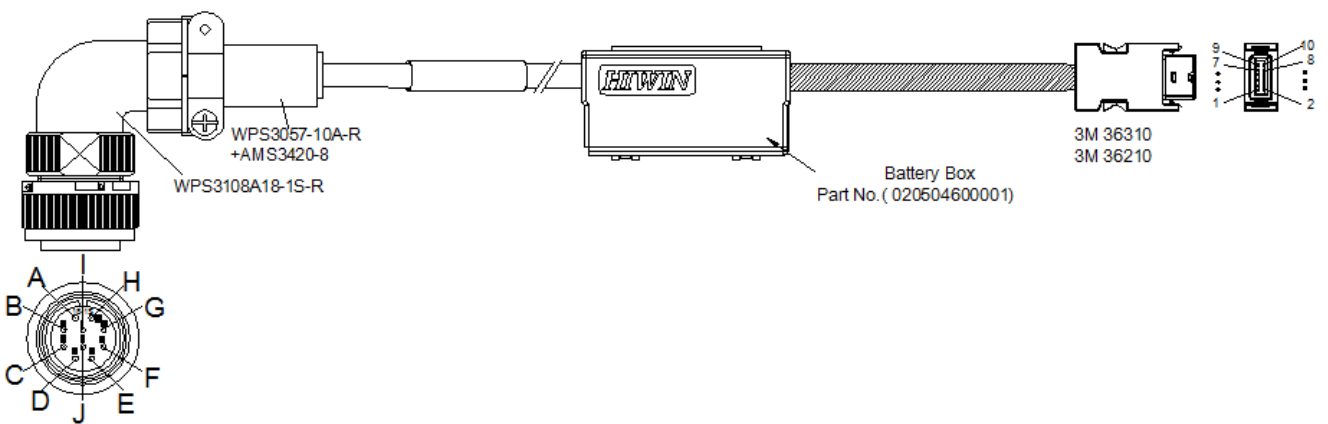

Figure 5.2.1.3.3



■ 23 bit absolute encoder cable battery replacement procedures

When battery voltage drops to 2.7 V or below, alarm encoder battery undervoltage (AL.810) occurs. Then the battery must be replaced.

(1) When battery is installed on controller

- Step1: Turn on the control power of the servo drive only.
- Step2: Remove the battery and installed a new battery.
- Step3: Turn off the control power of the servo drive to clear alarm AL.810.
- Step4: Turn on the control power of the servo drive again.
- Step5: Check if the alarm is cleared. Then, the servo drive can be operated normally.

(2) Encoder cable with battery box is used

- Step1: Turn on the control power of the servo drive only.
- Step2: Open the lid of the battery box.
- Step3: Remove the battery and installed a new battery.
- Step4: Close the lid.
- Step5: Turn off the control power of the servo drive to clear alarm AL.810.
- Step6: Turn on the control power of the servo drive again.
- Step7: Check if the alarm is cleared. Then, the servo drive can be operated normally.

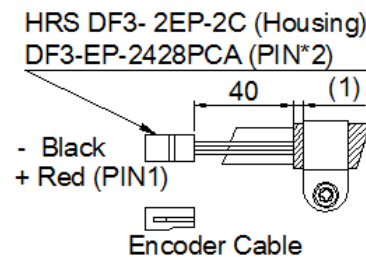
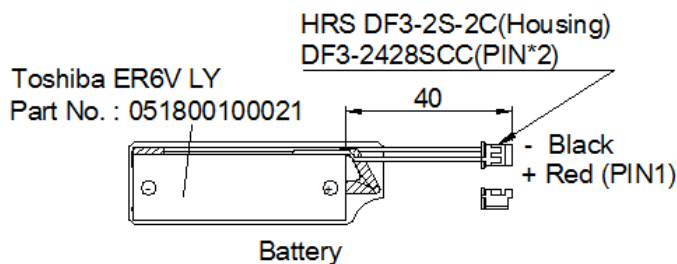
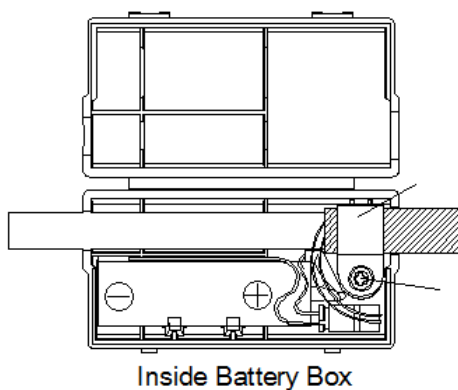

Figure 5.2.1.3.4

■ Battery lifespan calculation

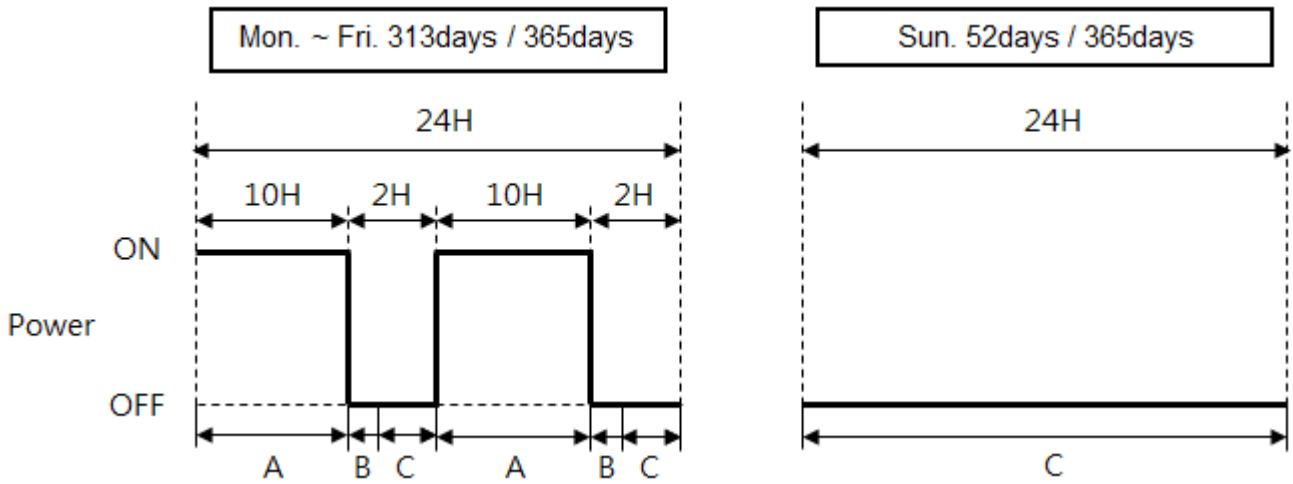

Figure 5.2.1.3.5

Table 5.2.1.3.3

Function	Power consumption
A: Power on	7 uA
B: Momentary outage	150 uA
C: Power off operation	110 uA

$$\text{power consumption (year)} = (10\text{H} \times A + 0.0014\text{H} \times B + 2\text{H} \times C) \times 2 \times 313 + 24\text{H} \times C \times 52 = 319(\text{mAh})$$

$$\text{Battery life} = \frac{1440\text{mAh}}{319\text{mAh}} = 4.5(\text{year})$$

**5.2.1.4 Allowable bending radius**

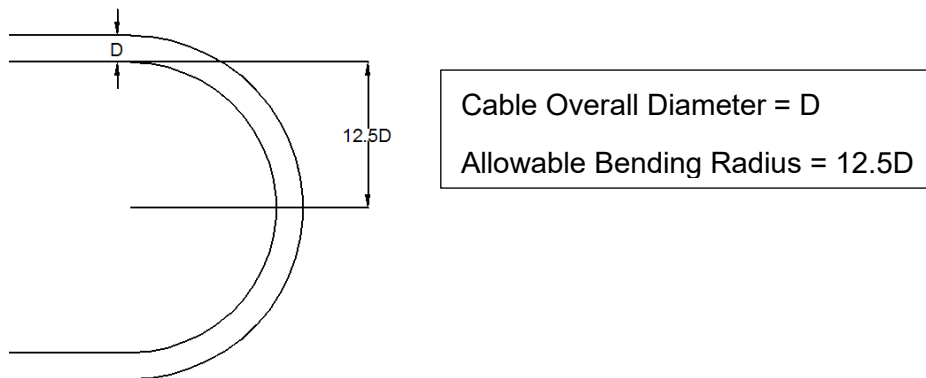

Figure 5.2.1.4.1

■ Outer diameter

Table 5.2.1.4.1

Item	Part No.	Outer diameter (mm)	Allowable bending radius (mm)
Extension power cable (50 W ~ 750 W)	HVPS04	8.5	106.25
Extension power cable (with brake) 50 W ~ 750 W	HVPS06	10.5	131.25
Extension power cable (1 kW / 2 kW)	HVPM04	10.5	131.25
Extension brake cable (1 kW / 2 kW)	HVPM02	5.2	65
Extension encoder cable (50 W ~ 2 kW)	HVE23	8	100

## 5.2.2 Electrical connection

Before connection, it is required to use HIWIN power cables and encoder cables, which have numerous advantages of UL/CSA authorization, extreme load capability and resistance as well as a design suitable for EMC.

### **DANGER**

#### **Danger from electric voltage!**



- ◆ Work can only be carried out by a qualified electrician and with the power supply disconnected!
- ◆ Before carrying out work on the AC servo motor, disconnect the power supply and protect it from being switched back on!
- ◆ Do not remove the cover, cables, or connector from AC servo motor while the power is ON.
- ◆ Do not touch wires or operate the equipment with wet hands.
- ◆ Do not use when wires are in contact with oil or water.
- ◆ Before starting to work, check with measuring device if any residual voltage is left in the parts of AC servo motor. If so, wait until all parts of system have been discharged.

### **WARNING**

#### **Risk of personal injury or damage to property.**



- ◆ Before using this product, please read the operation voltage marked in the specification labels and make sure that the supplied power meets product requirements.
- ◆ Please have professional electricians arrange the wiring.
- ◆ Make sure the wire distributions are executed properly or the servo motor will experience unexpected reactions.
- ◆ Please connect the power terminal and motor terminal securely.
- ◆ For wire distribution, the AC servo motor grounding terminal must be installed properly.
- ◆ Please check if the motor input, drive input and brake input voltage is correct. It is especially important to check if the power and signal wires connected to the encoder are correct. Incorrectly distributed wires can cause abnormal motor operation and cause damage or malfunction in motors and drives.
- ◆ Try to separate the motor power cable and the encoder power cable and signal cable. This is to prevent electrical signal coupling and noise (do not install the power and signal on the same circuit).
- ◆ Do not conduct voltage resistance test on the encoder. This can damage the encoder.
- ◆ Do not connect the servo motor U, V, W directly to the input power.
- ◆ Install an external emergency stop circuit to ensure that power can be shut off in emergency

situation.

- ◆ Do not touch the terminal within 5 minutes after power off because the residual high voltage may remain in the connector.

## **WARNING**

### **Risk of short circuit caused by liquid, lubricant or pollutions.**



- ◆ When installing or replacing drive components, provide open sides of power connectors with protective caps.
- ◆ Do only open terminal boxes for connection purpose and close them immediately after the connection is done.

## **CAUTION**

### **Risk of personal injury.**



- ◆ Ensure the AC servo motor is correctly grounded.
- ◆ The resistance of grounding terminal connection shall be less than 10Ω when the input voltage of the drive is 400V; less than 50Ω when it is 220V; less than 100Ω when it is 110V.

(This page is intentionally left blank.)

# 6. Commissioning

---

6.	Commissioning.....	6-1
6.1	Commissioning .....	6-2
6.1.1	Flow chart for tuning .....	6-2
6.1.2	Tuning function.....	6-3
6.1.3	Precautions during tuning .....	6-4

## 6.1 Commissioning

### 6.1.1 Flow chart for tuning

Tuning can optimize the response of motor by adjusting servo gains. Servo gains are set by several parameters (position loop gain, velocity loop gain, filter, vibration suppression and feedforward compensation). Gain-related parameters can affect the performance of each other, so please consider the balance among their settings. The default settings of gain-related parameters are set to have relatively stable servo gains. Use tuning functions provided in E series servo drive to improve response performance according to your mechanism and operating condition. The flow chart for tuning procedure is as below. For the sections mentioned in figure 6.1.1.1, please refer to “E1 Series Servo Drive User Manual” and “E2 Series Servo Drive User Manual.”

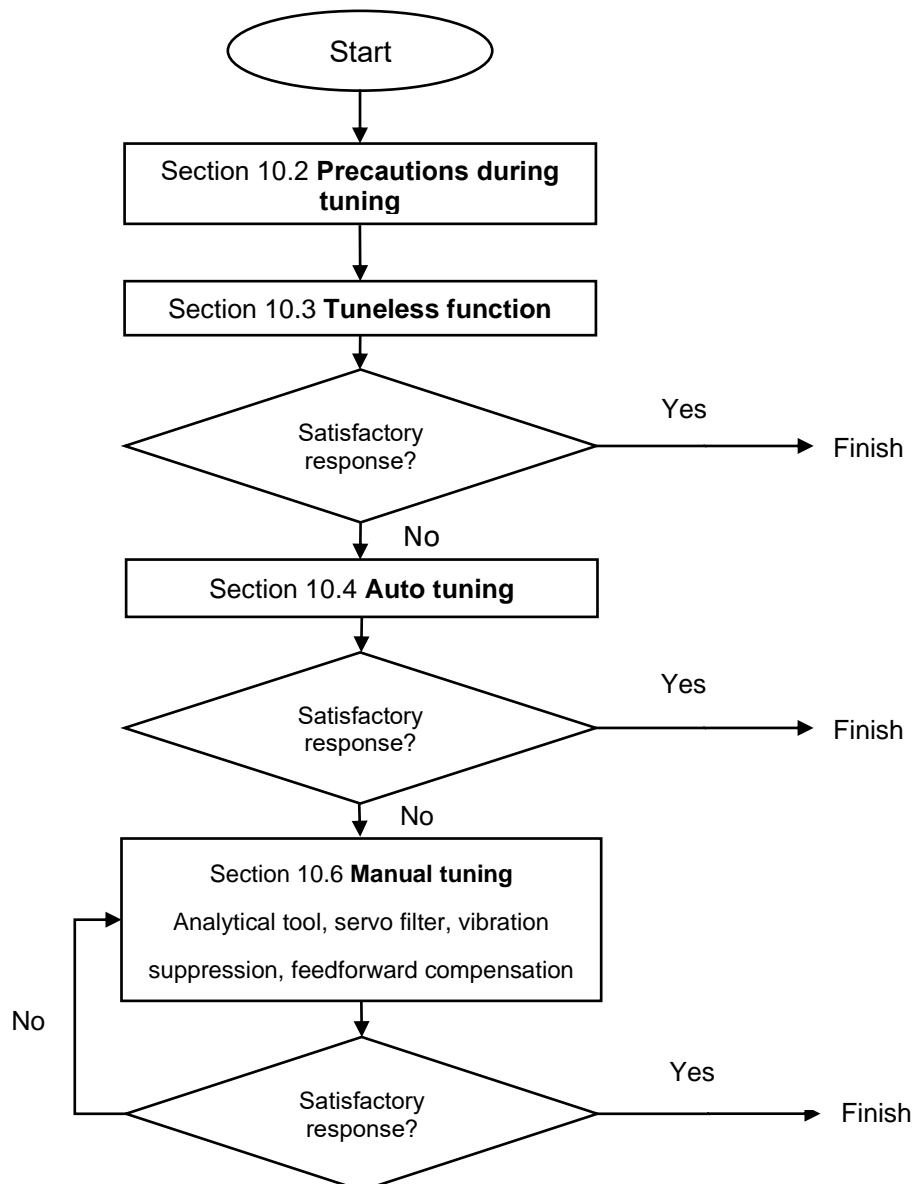

Figure 6.1.1.1



## 6.1.2 Tuning function

The tuning functions provided in E series servo drive are listed in table below. For the sections mentioned in table 6.1.1.1, please refer to “E1 Series Servo Drive User Manual” and “E2 Series Servo Drive User Manual.”

Table 6.1.2.1

Tuning Function	Description	Control Mode	Reference
Tuneless	Tuneless function can be applied for any machine type and load variation to have stable response performance.	Velocity mode, position mode and torque mode	Refer to section 10.3.
Auto tuning	The servo drive automatically adjusts control loops without receiving commands from the controller. During the process, parameters will be adjusted according to mechanical characteristics.	Velocity mode, position mode and torque mode	Refer to section 10.4.
Manual tuning	Manually adjust servo gains to improve response.	Velocity mode, position mode and torque mode	Refer to section 10.6.
Feedforward Compensation	Use model-based control provided by the servo drive.	Position mode	Refer to section 10.6.5.
Vibration suppression	Suppress 1 Hz~100 Hz low-frequency vibration caused by machine vibration during positioning.	Position mode	Refer to section 10.6.4.
Ripple compensation	Suppress low speed ripple caused by the magnetic poles of motor.	Velocity mode and position mode	Refer to section 10.6.5.
Friction compensation	Compensate viscous friction fluctuation and regular load fluctuation.	Velocity mode and position mode	Refer to section 10.6.6.

### 6.1.3 Precautions during tuning

**CAUTION**

- ◆ Ensure the precautions below are followed when tuning.
  - (1) Do not touch the rotating parts of the motor at servo ON.
  - (2) Ensure emergency stop can be activated anytime when motor is in operation.
  - (3) Perform tuning after trial operation is completed.
  - (4) For safety, install a stopping device on mechanism.

For settings to be checked, please refer to servo drive section 10.2.1, 10.2.2 and 10.2.3 in “E1 Series Servo Drive User Manual” and “E2 Series Servo Drive User Manual.”

## 7. Maintenance and cleaning

---

7.	Maintenance and cleaning .....	7-1
7.1	Maintenance .....	7-2
7.2	Cleaning.....	7-4
7.2.1	Test run .....	7-5

## 7.1 Maintenance

Table 7.1.1

Tool or equipment	<ul style="list-style-type: none"> <li>✓ Screwdriver or torque wrench</li> <li>✓ Lubricant</li> <li>✓ Insulation resistance meter</li> </ul>
Personal protective equipment	<ul style="list-style-type: none"> <li>✓ Safety shoes</li> <li>✓ Protective helmet</li> <li>✓ Protective gloves</li> </ul>

Please read all safety instructions before performing motor maintenance.

 **DANGER**



**Danger from electric voltage!**

- ◆ Work can only be carried out by a qualified electrician and with the power supply disconnected!
- ◆ Before carrying out work on the AC servo motor system, disconnect the power supply and protect it from being switched back on!

 **DANGER**



**Danger from strong magnetic fields!**

- ◆ Strong magnetic fields around AC servo motor pose a health risk to persons with implants (e.g., cardiac pacemakers) that are affected by magnetic fields.
- ◆ People with implants are affected by magnetic fields should maintain a safe distance of at least 1 m from the AC servo motor.

 **DANGER**



**Risk of crushing from strong forces of attraction!**

- ◆ The shaft and magnetizable objects may accidentally attract each other and collide!
- ◆ Do not underestimate the attraction force and operate carefully.
- ◆ Wear safety gloves when necessary.
- ◆ It requires at least two people to cooperate during operation.
- ◆ If users has not reach the rotor installation during assembly, please place the rotor in a safe and proper place.
- ◆ Do not take multiple motors at once.
- ◆ Do not bring any magnetizable materials close to the shaft! If the tool must be magnetized, please hold it firmly with both hands and slowly approach the shaft!

**⚠ WARNING**



**Risk of personal injury or damage to property.**

- ◆ Do not disassemble the AC servo motor or drive.
- ◆ Do not attempt to change the wiring while the power is ON.
- ◆ When replacing the servo motor or drive, resume operation only after transferring the previous servo system parameters to the new servo system.

**⚠ WARNING**



**Risk of personal injury.**

- ◆ Lifting heavy loads may damage your health.
- ◆ For total load of package with AC servo motor weight over 20 kg, use a hoist of an appropriate size when positioning heavy loads!
- ◆ Check applicable occupational health and safety regulations when handling suspended loads!

**⚠ CAUTION**



**Risk of Physical Damage to Watches and Magnetic Storage Media.**

- ◆ Strong magnetic force may destroy watches and magnetizable data storage media near the AC servo motor!
- ◆ Do not bring watches or magnetizable data storage media in the vicinity (<300 mm) of the AC servo motor!

**⚠ WARNING**



**Risk of Personal Injury or damage to property.**

- ◆ Obstacle removal and maintenance can only be performed by HIWIN MIKROSYSTEM technicians or authorized dealers, and with appropriate protective equipment.
- ◆ Do not perform any maintenance actions while the motor is running. The controller must stop the motor first.
- ◆ Please turn off the power and main switch of the machine (Please refer to the machine manufacturer's instructions for operation).
- ◆ After the power is turned off, there will be residual voltage in the system within a few minutes. Make sure that the power indicator for the servo drive is off, and then use a test instrument to check the voltage between the terminals on the servo unit before starting inspection work.
- ◆ Clean the metal particles on the motor regularly.

■ Replacement of consumable parts

The usable life of the parts is as shown below. However, as the method of use and environmental conditions change, the parts must be changed if abnormalities are discovered. Users can commission the dealers or the sales representatives of HIWIN MIKROSYSTEM to repair or purchase the parts.

Part name	Standard usable life	Check remarks
Bearing	20,000 HR	Check the bearing for abnormal noise or vibration.
Oil seal	5,000 HR	Check the flange opening for oil leak.
Brake	20,000 HR	Check for abnormal noise and vibration. Test if the braking and release time is normal and check the changes of power supply during operation.

## 7.2 Cleaning

Table 7.2.1

Tool or equipment	<ul style="list-style-type: none"> <li>✓ Rag</li> <li>✓ 70% alcohol</li> </ul>
Personal protective equipment	<ul style="list-style-type: none"> <li>✓ Safety shoes</li> <li>✓ Protective helmet</li> <li>✓ Protective gloves</li> <li>✓ Protective goggles</li> </ul>

■ Frequency of the inspections / tests / maintenance

AC servo motor is a rotary actuator that can precisely control angular position, velocity and acceleration. Improper operation or incorrect application environment will shorten the life of the motor or even damage it. It is recommended to conduct measurement and maintenance every quarter, please refer to the following instructions for maintenance and inspection:

- (1) The detection mechanism or electrical connection must not be loosened.
- (2) Detect possible wear or aging of the cable.
- (3) Clean the dirt on the surface of the motor cover, brake cover, encoder cover with 70% alcohol.
- (4) Use the insulation resistance meter to test the three-phase insulation resistance of the motor. It must meet the requirements of 500 VDC for 1 second, and  $>10M\Omega@25^{\circ}C$ . If the insulation resistance

decreases gradually at the same temperature compared with the previous measurements, it indicates that the motor is aging, which users should be aware of.

### **7.2.1 Test run**

The procedures of inspection before trial operation are provided in the following sections. Do not connect motor and mechanism while executing trial operation. If the motor cannot be removed from the mechanism, its load must be removed. The purpose of trial operation is to check the combination of the servo drive and motor as well as the wiring of servo drive. Perform inspection based on the motor in use.

(This page is intentionally left blank.)



# 8. Disposal

---

8.	Disposal .....	8-1
8.1	Waste disposal.....	8-2
8.1.1	General .....	8-2
8.1.2	Tools and equipment.....	8-3
8.1.3	Decommissioning.....	8-3
8.1.4	Disposal .....	8-4

## 8.1 Waste disposal

### 8.1.1 General

#### **DANGER**

##### **Danger from electric voltage!**

**Before and during assembly, disassembly and repair work, dangerous currents may flow.**



- ◆ Work can only be carried out by a qualified electrician and with the power supply disconnected!
- ◆ Before carrying out work on the AC servo motor system, disconnect the power supply and protect it from being switched back on!

#### **DANGER**

##### **Danger from strong magnetic fields!**



- ◆ Strong magnetic fields around AC servo motor pose a health risk to persons with implants (e.g., cardiac pacemakers) that are affected by magnetic fields.
- ◆ People with implants are affected by magnetic fields should maintain a safe distance of at least 1 m from the AC servo motor.

#### **CAUTION**

##### **Risk of Physical Damage to Watches and Magnetic Storage Media.**



- ◆ Strong magnetic force may destroy watches and magnetizable data storage media near the AC servo motor!
- ◆ Do not bring watches or magnetizable data storage media in the vicinity (<300 mm) of the AC servo motor!

### 8.1.2 Tools and equipment

Tool or equipment	<ul style="list-style-type: none"> <li>✓ Screwdriver or torque wrench</li> <li>✓ Box</li> <li>✓ Cart</li> </ul>
Personal protective equipment	<ul style="list-style-type: none"> <li>✓ Safety shoes</li> <li>✓ Protective helmet</li> <li>✓ Protective gloves</li> </ul>

### 8.1.3 Decommissioning

When disassembling or deactivating the motor, please follow the orders instructed below:

 **WARNING**

**Risk of personal injury or damage to property.**



- ◆ If users do not follow the orders to deactivate the servo motor, it may cause personal injury, death or property damage.
- ◆ Please disassemble or deactivate the motor according to the order below.

Step 1: Stop operating AC servo motor and wait for the drive power supply to discharge completely.

Step 2: Remove all power cables and signal cables.

Step 3: If necessary, isolate all power connections to avoid the risk of electric shock due to voltage generated by the rotating motor during disassembly, or braking torque due to short circuits.

Step 4: Clean the foreign matter, debris and dust on the motor.

Step 5: When there are fixing plates or self-designed fixing jigs for the motors, please use these plates/jigs to fix the motor.

Step 6: If the guiding fixture method is used, it is necessary to confirm that the related fixtures and configurations are installed.

Step 7: Remove all the fixtures around the machine. If the motor is fixed, it can be separated from the machine at the same time. If the guiding method is used, please remove the motor in the reverse order during assembly.

Step 8: Use the original packaging or a safe way to pack and store the motor correctly.

## 8.1.4 Disposal

Products need to be disposed according to the normal recycling process in accordance with laws and regulations.

### **WARNING**

#### **Risk of personal injury or damage to property.**



- ◆ If the servo motor or related components (especially the rotor with strong magnets) are not handled correctly, it may cause personal injury, death or property damage.
- ◆ Please ensure that the servo motor and related components are disposed correctly.

Appropriate disposal process:

- The permanent magnets in the rotor assembly must be completely demagnetized.
- The components to be recycled need to be disassembled:
  - (1). Electronic waste (e.g., encoder components, temperature control modules, etc.)
  - (2). Electrical waste (e.g., stator, cables, etc.)
  - (3). Scrap metal alloys (classified by metal)
  - (4). Insulation material
- No mixing with solvents, cold cleaning agents, or residue of paint.

# 9. Troubleshooting

---

9.	Troubleshooting.....	9-1
9.1	Troubleshooting .....	9-2
9.1.1	Troubleshooting form .....	9-3

## 9.1 Troubleshooting

Table 9.1.1

Symptom	Cause	Action
Motor cannot be rotated manually without connecting the controller	Mechanical interference	Remove interference.
	Motor three-phase short circuit	Fix three-phase short circuit.
Motor cannot rotate	Wrong cable wiring	Check the cable connected to the controller
	Current overload	Check if there are interfering objects and remove them; check if the brake is abnormal.
	Over temperature protection	Check the over temperature setting of the controller.
	Abnormal insulation resistance	Measure insulation resistance after cooling. Do three-phase to ground measurement of stators (U/V/W to PE): 500V <sub>DC</sub> 1 sec>10 MΩ@25°C If it does not reach 10 MΩ, please contact HIWIN MIKROSYSTEM.
Wrong rotating direction	Wrong controller setting	Check controller settings.
	Wrong motor power cable wiring	Interchange the two-phase power cables connected to the controller.
Burning smell	Wrong controller setting	Check controller settings.
	Wrong motor parameters	Check motor parameter settings.
Abnormal temperature of the motor housing	Wrong controller setting	Check controller settings.
	Wrong motor parameters setting	Check motor parameter settings.
	Abnormal operation of bearing	Check the installation.
Unstable rotation (vibration)	Insulation failure	Check the value of three-phase resistance to ground is large than 10 MΩ.
	Wrong encoder installation	Check installation stiffness of encoder.
	Wrong encoder signal	Check encoder connection.
	Wrong controller setting	Check controller settings.
	Wrong motor parameters setting	Check motor parameter settings.
Abnormal friction noise	Motor brake does not work	Check the brake.
	Imbalanced system	Check the dynamic balance.
	Loose system	Fix it tight again.

## 9.1.1 Troubleshooting form

In the event of a motor failure or error, this form assists users to provide essential details to HIWIN MIKROSYSTEM, which facilitates effective troubleshooting and repair, avoiding any possible and unnecessary downtime. Please complete the form.

Caution: Do not dismount the motor before performing all the required measurements.

### ■ Identification of Motor

Product code: \_\_\_\_\_

Serial number of motor (see nameplate): \_\_\_\_\_

Motor orientation:  Horizontal /  Vertical

Motor in service since (yyyy-mm-dd): \_\_\_\_\_

### ■ Failure Situation

Failure description: \_\_\_\_\_

Please describe the status when the motor is failed.

During commissioning stage, please describe:

\_\_\_\_\_

During normal operation stage (e.g., turning, milling, stalled), please describe:

\_\_\_\_\_

Other operation:

\_\_\_\_\_

Failure message from the drive:  No /  Yes

Rapid stop, please describe:

\_\_\_\_\_

Performance degradation (vibration, ripple, noise), please describe:

\_\_\_\_\_

Others, please describe:

\_\_\_\_\_

Did the same failure occur before?

No /  Yes, occurrence date (yyyy-mm-dd): \_\_\_\_\_, failure motor type: \_\_\_\_\_

■ **Electrical Troubleshooting**

Before starting the measurements below, switch off the drive’s power and disconnect the cable after the drive is discharged. Wait until the motor cools down to ambient temperature (25±5°C):

Check the entire wiring for any interruption or loose connection.

No /  Yes, abnormal position: \_\_\_\_\_

Measure line resistance: R<sub>UV</sub>: \_\_\_\_\_, R<sub>VW</sub>: \_\_\_\_\_, R<sub>UW</sub>: \_\_\_\_\_

Inspection of cables and connectors:

Any damage on cables/cable glands/cable connectors:  No /  Yes

Shaft inspection:

Is the motor shaft damaged?  No /  Yes, please describe: \_\_\_\_\_

■ **Operation Conditions**

Which component is attached to the motor?

None  Belt  Coupling  Screw  Linear guide way  Others: \_\_\_\_\_

■ **Appendix**

Please share all relative information with HIWIN MIKROSYSTEM for analyzing the problem (photos, NC records, damaged parts). List all the files and parts sent to HIWIN MIKROSYSTEM:

\_\_\_\_\_

■ **Contact Information**

Company/Institute/Department:

\_\_\_\_\_

Contact person:

\_\_\_\_\_

Email:

\_\_\_\_\_

Phone:

\_\_\_\_\_

Address:

\_\_\_\_\_







# 10. Declaration of incorporation

---

10.	Declaration of incorporation .....	10-1
10.1	Declaration of incorporation.....	10-2

## 10.1 Declaration of incorporation

	<p>大銀微系統股份有限公司                  台灣40852台中市精密機械園區                  精科中路6號                  Tel : +886-4-23550110                  Fax : +886-4-23550123</p>	<p>HIWIN MIKROSYSTEM CORP.                  No.6, Jingke Central Rd., Precision Machinery                  Park, Taichung 40852, Taiwan                  www.hiwinmikro.tw                  business@hiwinmikro.tw</p>															
																	
<h3>Declaration of Conformity</h3> <p>according to Low Voltage EC directive 2014/35/EU</p>																	
<p><b>Name and address of the manufacturer:</b>                  HIWIN MIKROSYSTEM CORP., No.6, Jingke Central Rd., Taichung Precision Machinery Park, Taichung 408226, Taiwan</p>																	
<p><b>Description and identification of the product:</b></p> <table border="0" style="width: 100%;"> <tr> <td style="width: 20%;">Product</td> <td>AC Servo Motor</td> </tr> <tr> <td>Identification</td> <td>Series: FR (50, 100, 200, 400, 750, 1000, 1200, 2000W), EM1 (50, 100, 200, 400, 750, 1000, 1200, 2000W)</td> </tr> </table>			Product	AC Servo Motor	Identification	Series: FR (50, 100, 200, 400, 750, 1000, 1200, 2000W), EM1 (50, 100, 200, 400, 750, 1000, 1200, 2000W)											
Product	AC Servo Motor																
Identification	Series: FR (50, 100, 200, 400, 750, 1000, 1200, 2000W), EM1 (50, 100, 200, 400, 750, 1000, 1200, 2000W)																
<p><b>The object of the declaration described above is in conformity with the relevant Union harmonization legislation Directives.</b></p> <table border="0" style="width: 100%;"> <tr> <td style="width: 20%;">2014/30/EU</td> <td>EMC directive</td> </tr> <tr> <td>2011/65/EU</td> <td>RoHS directive</td> </tr> </table>			2014/30/EU	EMC directive	2011/65/EU	RoHS directive											
2014/30/EU	EMC directive																
2011/65/EU	RoHS directive																
<p><b>References to the relevant harmonized standards used or references to the other technical specifications in relation to which conformity is declared</b></p> <table border="0" style="width: 100%;"> <tr> <td style="width: 20%;">EN 60204-1:2018</td> <td>Safety of machinery - Electrical equipment of machines - Part 1: General requirements</td> </tr> <tr> <td>EN 61000-6-2:2005</td> <td rowspan="2">Electromagnetic compatibility (EMC) - Part 6-2: Generic standards - Immunity for industrial environments</td> </tr> <tr> <td>EN 61000-6-2:2005/AC:2005</td> </tr> <tr> <td>EN 61000-6-4:2007</td> <td rowspan="2">Electromagnetic compatibility (EMC) - Part 6-4: Generic standards - Emission standard for industrial environments</td> </tr> <tr> <td>EN 61000-6-4:2007/A1:2011</td> </tr> <tr> <td>EN 61800-5-2:2007</td> <td>Adjustable speed electrical power drive systems - Part 5-2: Safety requirements - Functional</td> </tr> <tr> <td>EN 60034-1:2010</td> <td rowspan="2">Rotating electrical machines - Part 1: Rating and performance</td> </tr> <tr> <td>EN 60034-1:2010/AC:2010</td> </tr> <tr> <td>EN 60034-5:2001/A1:2007</td> <td>Rotating electrical machines - Part 5: Degrees of protection provided by the integral design of rotating electrical machines (IP code) - Classification</td> </tr> </table>			EN 60204-1:2018	Safety of machinery - Electrical equipment of machines - Part 1: General requirements	EN 61000-6-2:2005	Electromagnetic compatibility (EMC) - Part 6-2: Generic standards - Immunity for industrial environments	EN 61000-6-2:2005/AC:2005	EN 61000-6-4:2007	Electromagnetic compatibility (EMC) - Part 6-4: Generic standards - Emission standard for industrial environments	EN 61000-6-4:2007/A1:2011	EN 61800-5-2:2007	Adjustable speed electrical power drive systems - Part 5-2: Safety requirements - Functional	EN 60034-1:2010	Rotating electrical machines - Part 1: Rating and performance	EN 60034-1:2010/AC:2010	EN 60034-5:2001/A1:2007	Rotating electrical machines - Part 5: Degrees of protection provided by the integral design of rotating electrical machines (IP code) - Classification
EN 60204-1:2018	Safety of machinery - Electrical equipment of machines - Part 1: General requirements																
EN 61000-6-2:2005	Electromagnetic compatibility (EMC) - Part 6-2: Generic standards - Immunity for industrial environments																
EN 61000-6-2:2005/AC:2005																	
EN 61000-6-4:2007	Electromagnetic compatibility (EMC) - Part 6-4: Generic standards - Emission standard for industrial environments																
EN 61000-6-4:2007/A1:2011																	
EN 61800-5-2:2007	Adjustable speed electrical power drive systems - Part 5-2: Safety requirements - Functional																
EN 60034-1:2010	Rotating electrical machines - Part 1: Rating and performance																
EN 60034-1:2010/AC:2010																	
EN 60034-5:2001/A1:2007	Rotating electrical machines - Part 5: Degrees of protection provided by the integral design of rotating electrical machines (IP code) - Classification																
<p><b>This declaration of conformity is issued under the sole responsibility of the manufacturer.</b></p>																	
<table border="0" style="width: 100%;"> <tr> <td style="width: 30%; vertical-align: top;">                 Taichung 408226, Taiwan                   09.08.2022  <hr style="width: 100%;"/>                 (Place, Date)             </td> <td style="width: 30%; vertical-align: top;">                 YU, KAI-SHENG, Executive Vice President   <hr style="width: 100%;"/>                 (Surname, first name, and function of signatory)             </td> <td style="width: 40%; vertical-align: top; text-align: right;">   <hr style="width: 100%;"/>                 (Signature)             </td> </tr> </table>			Taichung 408226, Taiwan  09.08.2022 <hr style="width: 100%;"/> (Place, Date)	YU, KAI-SHENG, Executive Vice President  <hr style="width: 100%;"/> (Surname, first name, and function of signatory)	 <hr style="width: 100%;"/> (Signature)												
Taichung 408226, Taiwan  09.08.2022 <hr style="width: 100%;"/> (Place, Date)	YU, KAI-SHENG, Executive Vice President  <hr style="width: 100%;"/> (Surname, first name, and function of signatory)	 <hr style="width: 100%;"/> (Signature)															

# 11. Appendix

---

11.	Appendix.....	11-1
11.1	Glossary.....	11-2
11.2	Unit conversion .....	11-3
11.3	Tolerances and hypotheses .....	11-5
11.3.1	Tolerances .....	11-5
11.3.2	Hypotheses .....	11-5
11.4	Supplementary formula.....	11-6
11.5	Optional accessories .....	11-7
11.5.1	Accessory kit .....	11-7
11.5.2	Power supply filter and accessories.....	11-7
11.5.3	Accessories for absolute encoder .....	11-7
11.5.4	Regenerative resistor .....	11-7
11.6	Customer request form .....	11-8

## 11.1 Glossary

Parameters used in the manual are listed in the following table.

Table 11.1.1 Parameters on the data sheet

Motor parameter	Symbol	Unit	Description
Drive input voltage	V	V	Input voltage of the drive
Output power	P	W	Output power of the motor operating at rated point
Rated torque	T <sub>c</sub>	N·m	Output torque of the motor operating at rated point
Rated current	I <sub>c</sub>	Arms	Input current of the motor operating at rated point
Maximum torque	T <sub>p</sub>	N·m	Maximum torque that can be applied for about 400 ms at maximum current
Maximum current	I <sub>p</sub>	Arms	Maximum current
Rated speed	ω <sub>c</sub>	rpm	Velocity of the motor operating at rated point
Maximum speed	ω <sub>p</sub>	rpm	Maximum allowable velocity of the motor
Torque constant	K <sub>t</sub>	N·m/Arms	Relation of rated torque and motor line current at a motor temperature of 25°C
Voltage constant (back EMF constant)	K <sub>e</sub>	V/krpm	Root-mean-square (RMS) value of the induced motor voltage at a motor temperature of 25°C and 1,000 revolutions per minute (rpm)
Winding resistance	R	Ω	Measured winding resistance between two strands at 25 °C
Winding inductance	L	mH	Measured inductivity between two strands
Inertia of rotor without brake	J	Kg·m <sup>2</sup> (x10 <sup>-4</sup> )	Inertia of the rotor without the optional brake
Inertia of rotor with brake	J	Kg·m <sup>2</sup> (x10 <sup>-4</sup> )	Inertia of the rotor with the optional brake
Mass	M	kg	Mass of the motor
Insulation class	-	-	Insulation class according to DIN EN 60034-1
Protection class	-	-	IP protection mode according to EN 60034
Static friction torque	T <sub>b</sub>	N·m	Holding torque of the brake
Enabled current	I <sub>b</sub>	A	Continuous current of the brake
Brake input voltage	V <sub>b</sub>	V	Input voltage of the brake
Braking time	T <sub>o</sub>	ms	Duration until the brake applies
Release time	T <sub>r</sub>	ms	Duration until the brake releases

## 11.2 Unit conversion

To convert the unit in column B to the unit in column A, multiply by the corresponding figure in the table.

### ■ Mass

		B			
		g	kg	lb	oz
A	g	1	0.001	0.0022	0.03527
	kg	1000	1	2.205	35.273
	lb	453.59	0.45359	1	16
	oz	28.35	0.02835	0.0625	1

### ■ Angular velocity

		B			
		deg/s	rad/s	rpm	rps
A	deg/s	1	$1.745 \times 10^{-2}$	0.167	$2.777 \times 10^{-3}$
	rad/s	57.29	1	9.549	0.159
	rpm	6	0.105	1	$1.667 \times 10^{-2}$
	rps	360	6.283	60	1

### ■ Rotary inertia

		B			
		kg-m <sup>2</sup>	lb-in <sup>2</sup>	lb-ft <sup>2</sup>	oz-in <sup>2</sup>
A	kg-m <sup>2</sup>	1	3417.63	23.73	54644.81
	lb-in <sup>2</sup>	$2.926 \times 10^{-4}$	1	$6.943 \times 10^{-3}$	15.99
	lb-ft <sup>2</sup>	$4.214 \times 10^{-2}$	144.02	1	2302.73
	oz-in <sup>2</sup>	$1.83 \times 10^{-5}$	$6.254 \times 10^{-2}$	$4.34 \times 10^{-4}$	1

■ Torque

		B			
		N-m	lb-in	lb-ft	oz-in
A	N-m	1	8.851	0.7375	140.84
	lb-in	0.113	1	$8.333 \times 10^{-2}$	16
	lb-ft	1.355	11.99	1	191.94
	oz-in	$7.1 \times 10^{-3}$	$6.25 \times 10^{-2}$	$5.21 \times 10^{-3}$	1

■ Temperature

		B	
		°C	°F
A	°C	1	$(°F - 32) \times 5 / 9$
	°F	$(°C \times 9 / 5) + 32$	1

## 11.3 Tolerances and hypotheses

### 11.3.1 Tolerances

Table 11.3.1.1

Tolerances (mm)							
<6	6-30	30-120	120-300	300-600	600-1200	1200-2400	>2400
±0.1	±0.2	±0.3	±0.4	±0.5	±0.8	±1.0	±1.5

### 11.3.2 Hypotheses

Operation staff are trained in the safe operation practices for AC servo motor and have fully read and understood this user manual. Maintenance staff maintain and repair AC servo motor in such a way that they pose no danger to people, property or the environment.

### 11.4 Supplementary formula

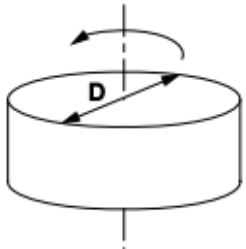
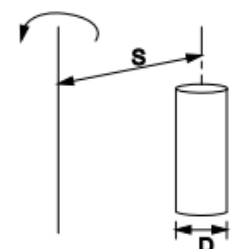
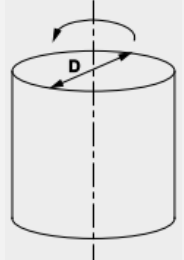
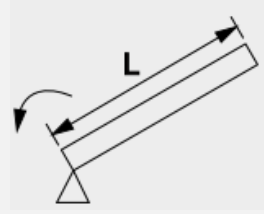
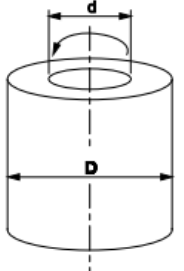
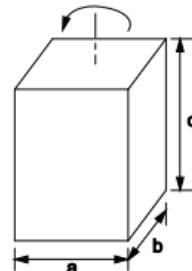
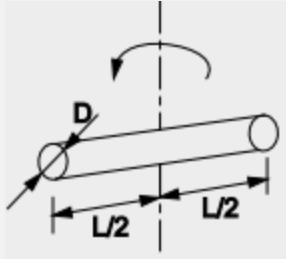
Shape	Inertia calculation formula	Shape	Inertia calculation formula
<p><b>Disk</b></p> 	$J = \frac{1}{8}MD^2$	<p><b>Separated</b></p> 	$J = \frac{1}{8}MD^2 + MS^2$
<p><b>Solid cylinder</b></p> 	$J = \frac{1}{8}MD^2$	<p><b>Straight rod</b></p> 	$J = \frac{1}{3}ML^2$
<p><b>Hollow cylinder</b></p> 	$J = \frac{1}{8}M(D^2 + d^2)$	<p><b>Prism</b></p> 	$J = \frac{1}{12}M(a^2 + b^2)$
<p><b>Uniform rod</b></p> 	$J = \frac{1}{48}M(D^2 + 4L^2)$		

- List of symbol :
- J : Inertia [kg·m<sup>2</sup>]
  - M : Mass [kg]
  - D : Outer diameter [m]
  - d : Inner diameter [m]
  - L : Length [m]
  - a, b, c : Side length [m]
  - S : Distance [m]

If mass (M [kg]) is unknown, calculate it with the following formula :

Mass M[kg] = Density ρ [kg/m<sup>3</sup>] x Volume V[m<sup>3</sup>]

Density of each material

- Iron ρ = 7.9 x 10<sup>3</sup> [kg/m<sup>3</sup>]
- Brass ρ = 8.5 x 10<sup>3</sup> [kg/m<sup>3</sup>]
- Aluminum ρ = 2.8 x 10<sup>3</sup> [kg/m<sup>3</sup>]



## 11.5 Optional accessories

For the connection of accessories from section 11.5.1 to 11.5.2 please refer to “E1 Series Servo Drive User Manual” and “E2 Series Servo Drive User Manual.”

### 11.5.1 Accessory kit

The accessory kit of E series servo drive are included when the servo drives are shipped out; the accessory kit of Excellent Smart Cube (ESC) is included when ESC is shipped out.

For the contents inside the accessory kit, please refer to “E1 Series Servo Drive User Manual” and “E2 Series Servo Drive User Manual.”

### 11.5.2 Power supply filter and accessories

Please refer to “E1 Series Servo Drive User Manual” and “E2 Series Servo Drive User Manual.”

### 11.5.3 Accessories for absolute encoder

Table 11.5.3.1

Name	HIWIN Part Number	Description
Lithium battery	051800100013	Voltage: 3.6 VDC
Battery box	051800400029	Battery box for the extension cable of absolute encoder

### 11.5.4 Regenerative resistor

Please refer to “E1 Series Servo Drive User Manual” and “E2 Series Servo Drive User Manual.”

## 11.6 Customer request form

\*Require

*Customer		Date:
Email		Contact person:
Drive Series	<input type="checkbox"/> E1 <input type="checkbox"/> E2	Title:
*AC Motor Series	Middle inertia : <input type="checkbox"/> 50 W <input type="checkbox"/> 100 W <input type="checkbox"/> 200 W <input type="checkbox"/> 400 W <input type="checkbox"/> 750 W <input type="checkbox"/> 1000 W <input type="checkbox"/> 1200 W <input type="checkbox"/> 2000 W	Note:
*Key	<input type="checkbox"/> No <input type="checkbox"/> Yes	
*Brake	<input type="checkbox"/> No <input type="checkbox"/> Yes	
*Seal	<input type="checkbox"/> No <input type="checkbox"/> Yes	
AC input voltage(V)	<input type="checkbox"/> Single phase 220V <input type="checkbox"/> Three phase 220V	
*Servo motor connecting wire	Motor power (flexure strength) Cable length : <input type="checkbox"/> 3M <input type="checkbox"/> 5M <input type="checkbox"/> 7M <input type="checkbox"/> 10M Encoder (flexure strength) Cable length : <input type="checkbox"/> 3M <input type="checkbox"/> 5M <input type="checkbox"/> 7M <input type="checkbox"/> 10M	
*Related accessory requirements	<input type="checkbox"/> Pulse Wire <input type="checkbox"/> USB cable <input type="checkbox"/> Single phase filter <input type="checkbox"/> Three phase filter	
*Control mode	<input type="checkbox"/> Position control <input type="checkbox"/> Velocity control <input type="checkbox"/> Torque control <input type="checkbox"/> EtherCAT(CoE) <input type="checkbox"/> Other	
Match method	<input type="checkbox"/> Slide/model no: _____ <input type="checkbox"/> Reducer/reduction ratio: _____ <input type="checkbox"/> Timing belt <input type="checkbox"/> Gear rack <input type="checkbox"/> Ball screw/guiding distance: _____ Screw outer diameter: _____	
Host	<input type="checkbox"/> PLC/manufacture: _____ model: _____ <input type="checkbox"/> Axis card/manufacture: _____ model: _____	
<b>Special Needs</b>		
Installation	<input type="checkbox"/> Horizontal <input type="checkbox"/> Vertical	
Speed requirement		
Acceleration requirement		
Weight requirement		
Recommended specifications: (Filled in by HIWIN MIKROSYSTEM or authorized agents.)		